

Bulk locality from the celestial amplitude

Chi-Ming Chang^{1,2*}, Yu-tin Huang^{3,4†}, Zi-Xun Huang^{3‡} and Wei Li^{3◦}

1 Yau Mathematical Sciences Center (YMSC), Tsinghua University, Beijing, 100084, China

2 Beijing Institute of Mathematical Sciences and Applications (BIMSA),
Beijing, 101408, China

3 Department of Physics and Center for Theoretical Physics,
National Taiwan University, Taipei, Taiwan 106

4 Physics Division, National Center for Theoretical Sciences, Taipei 10617, Taiwan

* cmchang@tsinghua.edu.cn, † yutinyt@gmail.com,
‡ r09222060@ntu.edu.tw, ◦ r07222072@ntu.edu.tw

Abstract

In this paper, we study the implications of bulk locality on the celestial amplitude. In the context of the four-point amplitude, the fact that the bulk S-matrix factorizes locally in poles of Mandelstam variables is reflected in the imaginary part of the celestial amplitude. In particular, on the real axis in the complex plane of the boost weight, the imaginary part of the celestial amplitude can be given as a positive expansion on the Poincaré partial waves, which are nothing but the projection of flat-space spinning polynomials onto the celestial sphere. Furthermore, we derive the celestial dispersion relation, which relates the imaginary part to the residue of the celestial amplitude for negative even integer boost weight. The latter is precisely the projection of low energy EFT coefficients onto the celestial sphere. We demonstrate these properties explicitly on the open and closed string celestial amplitudes. Finally, we give an explicit expansion of the Poincaré partial waves in terms of 2D conformal partial waves.



Copyright C.-M. Chang *et al.*

This work is licensed under the Creative Commons

[Attribution 4.0 International License](https://creativecommons.org/licenses/by/4.0/).

Published by the SciPost Foundation.

Received 15-09-2021

Accepted 03-05-2022

Published 27-05-2022

doi:[10.21468/SciPostPhys.12.5.176](https://doi.org/10.21468/SciPostPhys.12.5.176)



Check for
updates

Contents

1	Introduction	2
2	Review of the four-point celestial amplitude	5
2.1	Space-time to Celestial sphere “kinematics”	5
2.2	Implications of UV/IR behavior of $T(\omega, z)$	8
2.3	Example: The massive scalar exchange	9
3	The imaginary part of the celestial amplitude	10
3.1	Bulk-locality to the imaginary part of $\Psi(\beta, z)$	10
3.2	Positivity in $\text{Im}[\Psi(\beta, z)]$	12
3.3	Poincaré partial wave expansion	14

4	Open and closed string celestial amplitudes	16
4.1	Convergent regions in string theory	16
4.2	$\text{Im} \Psi(\beta, z)$ in string theory	18
5	Analytic continuation in z	20
5.1	The scalar example	21
5.2	General analysis	21
6	Celestial dispersion relation	24
6.1	Celestial dispersion relation in string theory	27
6.2	OPE limit	28
7	Conclusion and outlook	30
A	Four-point helicity amplitude	31
B	Poincaré generators on single particle states	32
C	Analytic continuation of the string amplitudes	32
D	Conformal partial wave representation	33
E	Computation of $C_{\Delta_1, \Delta_2; \Delta, \ell}^{(J)}$	36
	References	37

1 Introduction

In recent years, there has been steady progress on understanding the 2D holographic description of 4D flat-space scattering amplitudes [1–21] introduced by the pioneering work [1, 4], where one replaces the asymptotic state of the scattering amplitudes with boost eigenstates. In particular, the action of the Lorentz group $SL(2, \mathbb{C})$ on the kinematic data is recast into the Möbius transform on the celestial sphere, and the scattering amplitude is reinterpreted as a correlation function for some two-dimensional conformal field theory (CFT), termed the celestial amplitude. For amplitudes of massless external particles, this change of basis is implemented by a Mellin transform and the quantum numbers of the primary operator (h, \bar{h}) is related to the helicity (ℓ) of the external particle as $\ell = h - \bar{h}$, while the dimension $\Delta = h + \bar{h}$ is in-principle unconstrained.¹

As the celestial amplitudes (denoted as $\tilde{\mathcal{A}}_n$ for n states) are defined on boost eigenstates, which superpose all energies, the usual Wilsonian decoupling of UV/IR physics no longer applies and is only well-defined for theories equipped with a UV completion. This combined with the lack of local observables in quantum gravity, makes the celestial amplitude the prime arena to study general properties of consistent quantum gravity theories [21]. Motivated by this, it will be desirable to derive the general set of consistency conditions for $\tilde{\mathcal{A}}$.

The analytic properties of flat-space amplitude is an intensely studied subject and is relatively well-understood within the realm of perturbation theory. Thus, the “projection” of these properties onto the celestial sphere should serve as the primary constraint. For massless

¹Completeness relation of the conformal partial waves requires $\Delta = 1 + i\mathbb{R}$.

amplitudes, one of the simplest universal behaviors are the soft limits. However, due to the superposition of all energies, for $\tilde{\mathcal{A}}_n$ the fate of soft theorems were unclear. The first progress toward elucidating the image of flat-space soft theorems were taken in [14, 15, 22], where the limit was realized in the limit where the conformal dimensions are taken to 1. More precisely, these “conformal soft limits” of the celestial amplitudes lead to various conformal Ward identities associated with the holomorphic currents that generate the Kac-Moody symmetry in gauge theory [15], or the BMS supertranslation and the Virasoro symmetries in gravity [16, 19]. The conformal soft theorems then constrain the leading operator product expansion (OPE) coefficients in the celestial CFT [18].

On the other hand, the actions of the Poincaré symmetry on the celestial sphere are explicitly worked out in [12], and their constraints on the four and lower point celestial amplitudes are investigated in detailed in [17]. As a consequence a new set of expansion basis for $\tilde{\mathcal{A}}_4$, the Poincaré (relativistic) partial waves, was proposed in [20] analogous to the conformal partial wave expansion of four-point functions in CFT.

The above progresses focuses on the various symmetry properties of the celestial amplitudes and the constraints followed from them. An obvious gap is the role of flat-space factorization, which encodes *locality*, through where singularity might occur, and unitarity that governs the residue or discontinuity across the singularity. Indeed it is often the case that these considerations alone are sufficient to completely determine the flat-space amplitude. In view of this one would like to ask:

$$\text{How does the bulk-locality reflect on celestial amplitudes?} \tag{1}$$

Limit analysis was done for three-dimensional scalar exchange [6], as well as four-dimensional massive external legs [2]. In this paper, we aim to address this question in general for the four-point massless celestial amplitudes.

Poincaré invariance fixes the form of $\tilde{\mathcal{A}}_4$ up to a function that depends only on the real conformal cross ratio $z = \bar{z} = \frac{z_{12}z_{34}}{z_{13}z_{24}}$, the total conformal dimension (boost weight) $\beta = \Delta_1 + \Delta_2 + \Delta_3 + \Delta_4 - 4$, and the helicities ℓ_i , for $i = 1, \dots, 4$ of the external particles [12, 17].

The resulting function $\Psi(\beta, \ell_i, z)$ is related to the scattering amplitude in the plane wave basis by a Mellin transform

$$\Psi(\beta, \ell_i, z) \propto \int_0^\infty d\omega \omega^{\beta-1} T_{\ell_i}(s, t), \tag{2}$$

where ω is the center of mass energy and $T_{\ell_i}(s, t)$ is the flat-space amplitude stripped off the momentum conservation delta function and a kinematic phase. For fixed $\{\ell_i\}$ the we have a function of two variables (β, z) , replacing the flat-space parameterization (s, t) . It was argued in [21] that the function is analytic in β except for integer values on the real axes. The poles for $\beta = -2\mathbb{Z}^+$ are controlled by the Wilson coefficients of the low energy EFT with the degree of the poles determined by the IR running. For $\beta = 2\mathbb{Z}^+$, these encodes the polynomial suppression of the UV amplitude. For theories of quantum gravity that latter singularities are expected to be absent due to black hole productions.

Note that while the four-point celestial amplitude is defined on the equator of the celestial sphere, its not a continuous function across the entire circle. Using the usual $SL(2, \mathbb{C})$ to fix three points to $(0, 1, \infty)$, the equator is divided into three regions corresponding to s, t, u -channel kinematics respectively. Each channel is named after the positive Mandelstam

variable, while the remaining two are negative in the physical region. Schematically, we have:

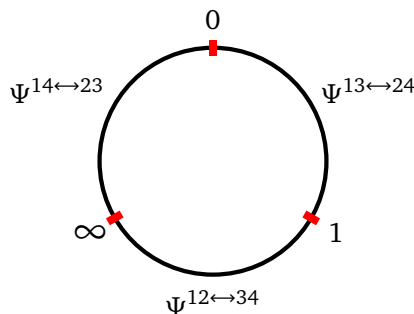

where the superscript on Ψ denotes the physical channel. Importantly, due to the β dependence of the Mellin transform, there are non-trivial monodromies across the three branch points $(0, 1, \infty)$, even for $\beta = 2\mathbb{Z}$. Thus, the three functions are in fact distinct and are not analytically connected, as first observed in the context of three-dimensions [6]. We will first demonstrate that due to bulk factorization, each function will acquire an imaginary piece reflecting the presence of thresholds in the physical channel, i.e. the channel with positive center of mass energy. In particular, the imaginary part of the celestial amplitude can be computed by extending the original Mellin integration to a fan-like contour that enclosed the positive real axis:

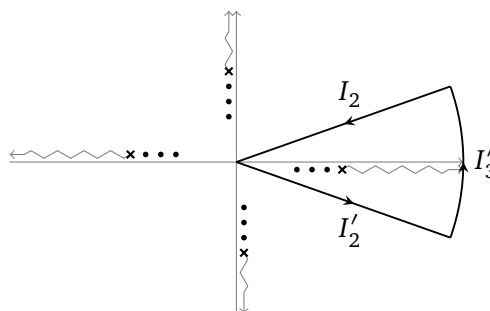

The contour integral captures the poles and discontinuities of the amplitude which can be expanded in the basis of orthogonal polynomials, Legendre polynomials for external scalars and Jacobi polynomials for gauge boson or graviton amplitudes. The projection of these polynomials onto the celestial sphere are then nothing but the Poincaré partial waves $\Phi_{m,J}(\beta, \ell_i, z)$ of mass m and spin J introduced in [20]. Thus, factorization singularities of the flat-space amplitude, in the physical channel, is projected into the imaginary part of the celestial amplitude and given by a sum of Poincaré partial waves, schematically,

$$\text{Im } \Psi(\beta, \ell_i, z) = \sum_a p_a \Phi_{m_a, J_a}(\beta, \ell_i, z). \tag{3}$$

If the external states are organized such that for the physical threshold corresponds to $a, b \rightarrow b, a$ process, then we further have $p_a > 0$, a reflection of unitarity.

Recently, it was shown that the EFT coefficients are constrained through dispersion relations in a fashion that reflects an underlying positive geometry, the EFThedron [23]. Since as previously mentioned, for $\tilde{\mathcal{A}}_4$ the poles on the negative β axes encodes the EFT coefficients, these must be expressible as some form of dispersion relation. However, while the usual flat-space dispersion relation involves imaginary pieces arising from thresholds in distinct channels, for the celestial amplitude the imaginary part at any point on the equator is given by thresholds in one channel along. To this end we analytic continue the celestial amplitudes outside their

physical defining regions to the “unphysical” regions. This allows us to establish the *celestial dispersion relation*, given as:

$$\frac{\pi}{2} \operatorname{Res}_{\beta \rightarrow -2n} [\Psi^{12 \leftrightarrow 34}(\beta, z)] = \operatorname{Im} [\Psi^{12 \leftrightarrow 34}(\beta, z) + (-1)^n \Psi^{13 \leftrightarrow 24}(\beta, z)] \Big|_{\beta \rightarrow -2n} \quad (z \geq 1), \quad (4)$$

where we’ve given the form in the region $z \geq 1$. Note that the RHS contains the imaginary part of both s and u -channel functions, where each can be defined in terms of the fan-like contour integral. We’ve explicitly verified these results for massive scalar exchange, as well as open and closed string amplitudes.

This paper is organized as follows. Section 2 reviews the kinematics of the four-point massless celestial amplitudes and the UV/IR behaviors onward. Section 3 computes explicitly the imaginary parts of the four-point massless celestial amplitudes, show their positive expansion in terms of the Poincaré partial waves, and check the crossing symmetry. Section 4 studies the example of the imaginary part of the open and closed string celestial amplitudes. Section 5 discusses the analytic continuation of the celestial amplitudes. Section 6 derives the celestial dispersion relation and verifies it for the example of the open and closed string amplitudes. Section 7 ends with a summary, further comments and future directions. Appendix A derives the general form of helicity amplitudes that satisfy the constraints from the Lorentz symmetry and momentum conservation. Appendix B reviews the action of the Poincaré generators on a massless single particle state. Appendix D expands the celestial amplitude and the Poincaré partial waves in terms of the conformal partial waves. Appendix E computes the three-point structure constant that shows up in the conformal partial wave expansion.

2 Review of the four-point celestial amplitude

In this section, we review general properties of the four-point celestial amplitude. We will focus on massless amplitudes \mathcal{A} , where the momenta are given as $p_i = \epsilon_i \omega_i q_i^\mu$, with $\epsilon = \pm$ denoting whether the particle is outgoing or incoming, and the null vector q^μ is parametrized by

$$q_i^\mu = (1 + |z_i|^2, 2\operatorname{Re}(z_i), 2\operatorname{Im}(z_i), 1 - |z_i|^2). \quad (5)$$

Later on, z_i will be the complex stereographic coordinate on the celestial sphere. Thus the amplitude \mathcal{A} instead of being a function of four momenta, is now a function of (ω_i, z_i) . The celestial amplitude is then simply the Mellin transform of helicity amplitudes:

$$\tilde{\mathcal{A}}_{\Delta_i, \ell_i}(z_i, \bar{z}_i) = \left(\prod_{i=1}^n \int_0^\infty d\omega_i \omega_i^{\Delta_i - 1} \right) \mathcal{A}_{\ell_i}(\omega_i, z_i), \quad (6)$$

where ℓ_i is the helicity of each leg.

2.1 Space-time to Celestial sphere “kinematics”

Let us consider in detail the transformation of flat-space scattering amplitudes to the celestial sphere. Since we will be interested in helicity amplitudes, it is natural to embed (ω_i, z_i) in the spinor variables $\epsilon_i \omega_i q_i^\mu(\sigma_\mu) = \lambda_i \tilde{\lambda}_i$, where:

$$\lambda_i = \epsilon_i \sqrt{2\omega_i} \begin{pmatrix} 1 \\ z_i \end{pmatrix}, \quad \tilde{\lambda}_i = \sqrt{2\omega_i} \begin{pmatrix} 1 \\ \bar{z}_i \end{pmatrix}. \quad (7)$$

The map is of course not unique, as any $U(1)$ rotation $\lambda \rightarrow e^{i\theta} \lambda$ and $\tilde{\lambda} \rightarrow e^{-i\theta} \tilde{\lambda}$ preserves the same null vector. The fact that the first component of λ ($\tilde{\lambda}$) is real, correspond to a specific

choice of frame. In this “canonical frame”, the Lorentz invariant spinor brackets take the form:

$$\langle ij \rangle = \varepsilon^{ab} \lambda_{j,a} \lambda_{i,b} = 2\epsilon_i \epsilon_j \sqrt{\omega_i \omega_j} (z_i - z_j), \quad [ij] = \varepsilon^{\dot{a}\dot{b}} \tilde{\lambda}_{j,\dot{a}} \tilde{\lambda}_{i,\dot{b}} = 2\sqrt{\omega_i \omega_j} (\bar{z}_i - \bar{z}_j). \quad (8)$$

Similarly the Mandelstam variable $s_{ij} = \langle ij \rangle [ji]$ is related to the distance $|z_{ij}|$ on the celestial sphere by

$$s_{ij} = -(p_i + p_j)^2 = -2p_i \cdot p_j = 4\epsilon_i \epsilon_j \omega_i \omega_j |z_{ij}|^2. \quad (9)$$

One can straight forwardly see that the $SL(2, \mathbb{C})$ Lorentz transformation acting on the spinors translate to the Möbius transformation acting on the complex plane z :

$$\begin{pmatrix} a & b \\ c & d \end{pmatrix} \lambda = e^{i\theta} \lambda', \quad z' = \frac{c + dz}{a + bz}, \quad \omega' = \omega |a + bz|^2, \quad e^{i\theta} = \frac{a + bz}{|a + bz|}. \quad (10)$$

Importantly, while the spinor products are Lorentz invariants, when considered in terms of the celestial coordinates they acquire a “little group” phase under $SL(2, \mathbb{C})$:

$$\begin{aligned} \langle ij \rangle' &= 2\epsilon_i \epsilon_j \sqrt{\omega'_i \omega'_j} (z'_i - z'_j) = 2e^{-i\theta_i} e^{-i\theta_j} \epsilon_i \epsilon_j \sqrt{\omega_i \omega_j} (z_i - z_j), \\ [ij]' &= 2\sqrt{\omega'_i \omega'_j} (\bar{z}'_i - \bar{z}'_j) = 2e^{i\theta_i} e^{i\theta_j} \sqrt{\omega_i \omega_j} (\bar{z}_i - \bar{z}_j). \end{aligned} \quad (11)$$

The origin of the extra phase is simple: as seen in eq.(7) an arbitrary $SL(2, \mathbb{C})$ transformation will rotate the spinors out of the canonical frame. Thus one requires a “compensating transformation” to restore it back. Since the amplitude transforms covariantly under little group transformations, manifested as helicity weights for each leg, one immediately deduce that the amplitude transform under $SL(2, \mathbb{C})$ as:

$$\mathcal{A}_{\ell_i}(\omega'_i, z'_i, \bar{z}'_i) = \left(\prod_j e^{2\ell_j \theta_j} \right) \mathcal{A}_{\ell_i}(\omega_i, z_i, \bar{z}_i). \quad (12)$$

The Mellin-transform in eq.(6) can then be viewed as changing from plane wave basis, to the conformal primary basis (or boost) [1, 4]. As a result under $SL(2, \mathbb{C})$ transformation $\tilde{\mathcal{A}}_{\Delta_i, \ell_i}$ transforms as:

$$\tilde{\mathcal{A}}_{\Delta_i, \ell_i}(z'_i, \bar{z}'_i) = \left(\prod_j (a + bz_j)^{\Delta_j + \ell_j} (\bar{a} + \bar{b}\bar{z}_j)^{\Delta_j - \ell_j} \right) \tilde{\mathcal{A}}_{\Delta_i, \ell_i}(z_i, \bar{z}_i). \quad (13)$$

Thus the n -point celestial amplitude $\tilde{\mathcal{A}}$ transforms like a n -point conformal correlator in two-dimensional conformal field theory

$$\langle O_{h_1, \bar{h}_1}(z_1, \bar{z}_1) \dots O_{h_n, \bar{h}_n}(z_n, \bar{z}_n) \rangle, \quad (14)$$

where the left-moving and right-moving conformal dimensions h_i and \bar{h}_i are

$$h_i + \bar{h}_i = \Delta_i, \quad h_i - \bar{h}_i = \ell_i. \quad (15)$$

The variables Δ_i in the Mellin transform (6) and the helicities ℓ_i become the total scaling dimensions and spins.

In this paper, our main focus is on the 4-point amplitude. $SL(2, \mathbb{C})$ conformal symmetry constrains the amplitude to the form

$$\tilde{\mathcal{A}}_{\Delta_i, \ell_i}(z_i, \bar{z}_i) = \frac{\left(\frac{z_{14}}{z_{13}}\right)^{h_3 - h_4} \left(\frac{\bar{z}_{24}}{z_{14}}\right)^{h_1 - h_2} \left(\frac{\bar{z}_{14}}{\bar{z}_{13}}\right)^{\bar{h}_3 - \bar{h}_4} \left(\frac{\bar{z}_{24}}{\bar{z}_{14}}\right)^{\bar{h}_1 - \bar{h}_2}}{z_{12}^{h_1 + h_2} z_{34}^{h_3 + h_4} z_{12}^{\bar{h}_1 + \bar{h}_2} \bar{z}_{34}^{\bar{h}_3 + \bar{h}_4}} f_{\Delta_i, \ell_i}(z, \bar{z}), \quad (16)$$

where the cross ratios z and \bar{z} and coordinate differences z_{ij}, \bar{z}_{ij} are

$$z = \frac{z_{12}z_{34}}{z_{13}z_{24}}, \quad \bar{z} = \frac{\bar{z}_{12}\bar{z}_{34}}{\bar{z}_{13}\bar{z}_{24}}, \quad z_{ij} = z_i - z_j, \quad \bar{z}_{ij} = \bar{z}_i - \bar{z}_j. \quad (17)$$

Translation invariance, or momentum conservation, further constrain the dependence on the cross-ratio [12, 17],

$$f_{\Delta_i, \ell_i}(z, \bar{z}) = (z - 1)^{\frac{\Delta_1 - \Delta_2 - \Delta_3 + \Delta_4}{2}} \delta(iz - i\bar{z}) \Psi(\Delta, \ell_i, z), \quad (18)$$

where $\Delta = \sum_i \Delta_i$. Due to the delta function $\delta(iz - i\bar{z})$, the celestial amplitude to be supported on the equator of the celestial sphere.

One can also derive (16) and (18) directly from the Mellin integral representation (6). First, as show in Appendix A by utilizing the momentum conservation and the $SL(2, \mathbb{C})$ symmetry, the four-point helicity amplitude take the form as

$$\mathcal{A}_{\ell_i}(\omega_i, z_i) = \delta^{(4)}(p_1 + p_2 + p_3 + p_4) \frac{\left(\frac{z_{14}\bar{z}_{13}}{\bar{z}_{14}z_{13}}\right)^{\frac{\ell_3 - \ell_4}{2}} \left(\frac{z_{24}\bar{z}_{14}}{\bar{z}_{24}z_{14}}\right)^{\frac{\ell_1 - \ell_2}{2}}}{\left(\frac{z_{12}}{\bar{z}_{12}}\right)^{\frac{\ell_1 + \ell_2}{2}} \left(\frac{z_{34}}{\bar{z}_{34}}\right)^{\frac{\ell_3 + \ell_4}{2}}} T_{\ell_i}(s, t), \quad (19)$$

where $s \equiv s_{12}, t = s_{14}$, and $u = s_{13}$ are the Mandelstam variables. The momentum conservation written in terms of the energies ω_i and the celestial sphere coordinates z_i and \bar{z}_i as

$$\delta\left(\sum_{i=1}^4 \epsilon_i \omega_i q_i\right) = \frac{8}{\Lambda^2 |\omega_4|} \delta(iz - i\bar{z}) \delta\left(\omega_1 + \epsilon_1 \epsilon_4 \frac{\Lambda^2 \omega_4}{z}\right) \times \delta\left(\omega_2 + \epsilon_2 \epsilon_4 \frac{\Lambda^2 \omega_4}{z(z-1)}\right) \delta\left(\omega_3 + \epsilon_3 \epsilon_4 \frac{\Lambda^2 \omega_4}{1-z}\right), \quad (20)$$

where we have used the $SL(2, \mathbb{C})$ transformation to fix the coordinates z_i to

$$z_1 = 0, \quad z_2 = z, \quad z_3 = 1, \quad z_4 = \Lambda \gg 1. \quad (21)$$

In this conformal frame, the celestial amplitude becomes

$$\begin{aligned} \tilde{\mathcal{A}}_{\Delta_i, \ell_i}(z_i, \bar{z}_i) &= 8 \Lambda^{-2\Delta_4} |z - 1|^{\frac{1}{2}(\Delta_1 - \Delta_2 - \Delta_3 + \Delta_4)} |z|^{-\Delta_1 - \Delta_2} \delta(iz - i\bar{z}) \\ &\times \theta(-\epsilon_1 \epsilon_4 z) \theta(\epsilon_2 \epsilon_4 z(1-z)) \theta(\epsilon_3 \epsilon_4 (z-1)) \\ &\times z^2 |z - 1|^{2 - \frac{\Delta}{2}} \int_0^\infty d\tilde{\omega}_4 \tilde{\omega}_4^{\Delta - 5} T_{\ell_i}\left(\frac{4\tilde{\omega}_4^2}{z-1}, -\frac{4\tilde{\omega}_4^2}{z}\right), \end{aligned} \quad (22)$$

where $\tilde{\omega}_4 = \Lambda^{-2} \omega_4$. Note that in the conformal frame (21) the z -dependent factor in front of $T(s, t)$ in (19) reduces to 1 by the delta functions. The Heaviside theta functions are there to ensuring the delta functions having support in the integration domain of ω_i . Indeed (22) reduces to (16) and (18) in the conformal frame (21) where one reads off $\Psi(\Delta, \ell_i, z)$ as

$$\begin{aligned} \Psi(\Delta, \ell_i, z) &= \theta(-\epsilon_1 \epsilon_4 z) \theta(\epsilon_2 \epsilon_4 z(1-z)) \theta(\epsilon_3 \epsilon_4 (z-1)) \\ &\times z^2 |z - 1|^{2 - \frac{\Delta}{2}} \int_0^\infty d\tilde{\omega}_4 \tilde{\omega}_4^{\Delta - 5} T_{\ell_i}\left(\frac{4\tilde{\omega}_4^2}{z-1}, -\frac{4\tilde{\omega}_4^2}{z}\right). \end{aligned} \quad (23)$$

Now due to the step functions, depending on the choice of incoming legs the cross-ratio z is constrained to different regions. Consider three distinct kinematic configuration distinguished by the incoming state being in s, u or t -channel,

$$\begin{aligned} 12 \leftrightarrow 34 : \quad &\epsilon_1 = \epsilon_2 = -\epsilon_3 = -\epsilon_4, \\ 13 \leftrightarrow 24 : \quad &\epsilon_1 = \epsilon_3 = -\epsilon_2 = -\epsilon_4, \\ 14 \leftrightarrow 23 : \quad &\epsilon_1 = \epsilon_4 = -\epsilon_2 = -\epsilon_3. \end{aligned} \quad (24)$$

Table 1: The physical regions, center of mass energy ω and Mandelstam variables in the three different kinematics.

kinematics	$12 \leftrightarrow 34$	$13 \leftrightarrow 24$	$14 \leftrightarrow 23$
physical region	$z \geq 1$ $s \geq 0 \geq u, t$	$1 \geq z \geq 0$ $u \geq 0 \geq s, t$	$0 \geq z$ $t \geq 0 \geq s, u$
ω	$\frac{2\tilde{\omega}_4}{\sqrt{z-1}}$	$\frac{2\tilde{\omega}_4}{\sqrt{z(1-z)}}$	$\frac{2\tilde{\omega}_4}{\sqrt{-z}}$
(s, u, t)	$(\omega^2, -\frac{1}{z}\omega^2, -\frac{(z-1)}{z}\omega^2)$	$(-z\omega^2, \omega^2, -(1-z)\omega^2)$	$(-\frac{(-z)}{1-z}\omega^2, -\frac{1}{1-z}\omega^2, \omega^2)$

The Heaviside theta functions in (23) will constrain the celestial amplitudes with the three different kinematics to have supports on three separate intervals on the equator of the celestial sphere,

$$12 \leftrightarrow 34 : z \geq 1, \quad 13 \leftrightarrow 24 : 0 \leq z \leq 1, \quad 14 \leftrightarrow 23 : z \leq 0. \quad (25)$$

It would be convenient to use the center of mass energy ω as the integration variable. We apply the changes of variables in the three different kinematics as

$$12 \leftrightarrow 34 : \omega^2 = \frac{4\tilde{\omega}_4^2}{z-1}, \quad 13 \leftrightarrow 24 : \omega^2 = \frac{4\tilde{\omega}_4^2}{z(1-z)}, \quad 14 \leftrightarrow 23 : \omega^2 = \frac{4\tilde{\omega}_4^2}{(-z)}. \quad (26)$$

The physical regions, changes of variables, and the corresponding parametrizations of the Mandelstam variables are summarized in Table 1. Note that we can also identify $z = \frac{2}{1-\cos\theta}$, where θ is the scattering angle and the limit $z \rightarrow \infty$ corresponds to the forward limit.

The celestial amplitude (23) in these three kinematics are then defined as:

$$\begin{aligned} \Psi^{12 \leftrightarrow 34}(\Delta, \ell_i, z) &= \frac{1}{2^{\Delta-7}} z^2 \int_0^\infty d\omega \omega^{\Delta-5} T_{\ell_i} \left(\omega^2, -\frac{(z-1)}{z} \omega^2 \right), & (z \geq 1), \\ \Psi^{13 \leftrightarrow 24}(\Delta, \ell_i, z) &= \frac{1}{2^{\Delta-7}} z^{\frac{\Delta}{2}} \int_0^\infty d\omega \omega^{\Delta-5} T_{\ell_i} \left(-z\omega^2, (z-1)\omega^2 \right), & (1 \geq z \geq 0), \\ \Psi^{14 \leftrightarrow 23}(\Delta, \ell_i, z) &= \frac{1}{2^{\Delta-7}} (-z)^{\frac{\Delta}{2}} (1-z)^{2-\frac{\Delta}{2}} \int_0^\infty d\omega \omega^{\Delta-5} T_{\ell_i} \left(\frac{z}{1-z} \omega^2, \omega^2 \right), & (0 \geq z). \end{aligned} \quad (27)$$

We stress that the celestial amplitude is *not* given by a single function $\Psi(\Delta, z)$ defined on the equator. Rather, there are three separate functions $\Psi^{12 \leftrightarrow 34}$, $\Psi^{13 \leftrightarrow 24}$ and $\Psi^{14 \leftrightarrow 23}$ that tile the equator.

In short, the function $\Psi^{ij \leftrightarrow kl}(\Delta, \ell_i, z)$ will be related to the amplitude via

$$\Psi^{ij \leftrightarrow kl}(\beta, \ell_i, z) = B^{ij \leftrightarrow kl}(z) \int_0^\infty d\omega \omega^{\beta-1} T_{\ell_i}^{ij \leftrightarrow kl}(\omega, z), \quad (28)$$

where using the notation of [21] we introduce $\beta = \Delta - 4$. $B^{ij \leftrightarrow kl}(z)$ denotes the prefactors in front of the integrals in (27), and $T_{\ell_i}^{ij \leftrightarrow kl}(\omega, z)$ equals to $T_{\ell_i}(s, t)$ with the parameterizations given in Table 1.

2.2 Implications of UV/IR behavior of $T(\omega, z)$

As stressed in [21], the analytic property of the celestial amplitude in complex β plane reflects the UV and IR properties of $T(\omega, z)$. Since we will be performing a Mellin transform with

respect to the center of mass energy ω , special attention will be paid to the region $\omega \rightarrow 0$ and ∞ for which the integral might diverge. In limit $\omega \rightarrow 0$, we probe the IR limit of $T(\omega, z)$. Suppressing the massless logs for now, the amplitude takes the form

$$T(\omega, z)|_{\omega \rightarrow 0} = T_{\text{massless}}(\omega, z) + \sum_{p=0}^{\infty} g_p(z) \omega^{2p}. \quad (29)$$

In s -kinematics, where $z \geq 1$, $g_p(z)$ are polynomial functions of at most degree $2p$ in $\frac{1-z}{z}$ reflecting the presence of contact interactions, i.e. higher dimension operators in the EFT description. The function $T_{\text{massless}}(\omega, z)$ summarizes the contribution from the massless particle exchange, which contain poles in $\frac{1-z}{z}$ and is of degree ω^0 or ω^2 for photon and graviton exchange respectively. Thus we see that the low energy amplitude is essentially a polynomial expansion in ω^2 . These generate single poles in β since

$$\Psi(\beta, z) \sim \int_0^\Lambda d\omega \omega^{\beta-1} (\omega^{2p}) + \dots = \frac{\Lambda^{\beta+2p}}{\beta+2p} + \dots, \quad (30)$$

where we only consider the part of the integral where $\omega \in [0, \Lambda]$. Thus we see that $\Psi(\beta, z)$ will have simple poles at $\beta = 0, -2, -4, \dots$. When the massless loops are involved, the simple poles are then promoted to higher degree as discussed in [21].

We now turn to the opposite limit, where $\omega \rightarrow \infty$ corresponding to fixed angle hard scattering,

$$s \rightarrow +\infty \quad \text{with} \quad \frac{s}{t} = \frac{z}{1-z} \quad \text{fixed}. \quad (31)$$

We will exam two asymptotic behaviors of $T(s, t)$ in this limit,

$$T(\omega, z) \sim \begin{cases} g_p(z) \omega^{2p} + g_{p-1}(z) \omega^{2p-2} + \dots & \text{power law,} \\ e^{-\omega^2 f(z)} & \text{exponential decay.} \end{cases} \quad (32)$$

As discussed in [21], the second scenario is expected for amplitudes in gravitational theories due to black hole production. Indeed this is the case for string theory, which we will discuss in detail later on. In such case $\Psi(\beta, z)$ is convergent for $\text{Re}[\beta] > 0$. For the power law, following similar analysis as the IR region we again arrive at poles for $\beta = -2p, -2p+2, -2p+4, \dots$. Now we would like to have a celestial amplitude that is meromorphic in β , thus having a region of convergence. From the previous IR analysis, we see that $\Psi(\beta, z)$ will have poles at $\text{Re}[\beta] \leq 0$, this suggest that we must have $p < 0$ such that there is a convergent region $0 < \text{Re}[\beta] < -p$.²

2.3 Example: The massive scalar exchange

As a simple example for the above analysis, consider a massless scalar ϕ coupled to a massive scalar X via a cubic coupling $g\phi^2 X$. The tree level 4-point scattering amplitude is

$$T(s, t) = -g^2 \left(\frac{1}{s - m^2 + i\epsilon} + \frac{1}{u - m^2 + i\epsilon} + \frac{1}{t - m^2 + i\epsilon} \right). \quad (34)$$

The Mellin integral (28) converges when β is bounded by

$$0 \leq \beta \leq 2. \quad (35)$$

²Indeed for $p = 0$ such as $\lambda\phi^4$ theory, the function $\Psi(\beta, z)$ cease to be meromorphic:

$$\int_0^\infty \frac{d\omega}{\omega} \omega^{i\epsilon} = \int_{-\infty}^\infty dx e^{i\epsilon x} = \delta(i\epsilon). \quad (33)$$

Indeed for the $12 \leftrightarrow 34$ kinematics, by rewriting $\Psi^{12 \leftrightarrow 34}(\beta, z)$ as integrating from $\omega = -\infty$ to $\omega = \infty$,

$$\Psi^{12 \leftrightarrow 34}(\beta, z) = \frac{2^{3-\beta} z^2}{(1 - e^{i\pi\beta})} \int_{-\infty}^{\infty} d\omega \omega^{\beta-1} T\left(\omega^2, -\frac{(z-1)}{z} \omega^2\right) \quad (36)$$

we can close the contour upward and pick up the residues giving [22]

$$\Psi_{\text{scalar}}^{12 \leftrightarrow 34}(\beta, z) = \frac{\pi g^2}{\sin \frac{\pi\beta}{2}} \left(\frac{m}{2}\right)^{\beta-2} z^2 \left[e^{\frac{1}{2}\pi i\beta} + z^{\frac{\beta}{2}} + \left(\frac{z}{z-1}\right)^{\frac{\beta}{2}} \right] \quad (z \geq 1). \quad (37)$$

Note that indeed starting from $\beta = 2$, one has simple poles at $\beta = 2, 4, 6, \dots$, reflecting the divergence in UV. Similarly, below $\beta = 0$, one has simple poles at $\beta = 0, -4, -6, \dots$, reflecting the EFT coefficients. The absence of $\beta = -2$ is due to the corresponding EFT operator vanishes on-shell, $s+t+u = 0$.

Importantly, there is a non-trivial imaginary part,³

$$\text{Im} \Psi_{\text{scalar}}^{12 \leftrightarrow 34}(\beta, z) = \pi g^2 \left(\frac{m}{2}\right)^{\beta-2} z^2 = 2^{3-\beta} \pi z^2 g^2 \text{Res}_{\omega=m} \left[\omega^{\beta-1} T(\omega, z) \right], \quad (38)$$

which is non-zero for any value of β . Furthermore for s -channel kinematics, only the physical threshold in the s -channel propagator contributes to imaginary part, while the t, u diagram only contribute to the real part. Thus we see that the imaginary part of the celestial amplitude encodes the information of bulk factorization. This will be the focus of the next section.

3 The imaginary part of the celestial amplitude

Here we would like to pose the following question: given a celestial amplitude $\Psi(\beta, z)$, what are the properties that reflect its origin as a local flat-space scattering amplitude. Already in the massive scalar case we've seen that for the s -channel kinematics, the fact that a massive scalar was being exchanged is reflected in the imaginary part of the celestial amplitude. In this section we will systematically study this property.

3.1 Bulk-locality to the imaginary part of $\Psi(\beta, z)$

The imaginary part of the amplitude is deeply rooted in causality, where the time ordered two point function introduces the $i\epsilon$ prescription for the Feynman propagator. Indeed this is the origin of the imaginary piece of the scalar exchange $\Psi^{12 \leftrightarrow 34}(\beta, z)$, appearing in the s -channel where the internal particle can be interpreted as on-shell and moving forward in time. Thus to capture the imaginary piece, it will be useful to consider the Mellin transform as a contour integral on the complex ω -plane.

Let us focus on the $12 \leftrightarrow 34$ kinematics. From previous discussions, we have seen that for $\Psi^{12 \leftrightarrow 34}(\beta, z)$ to be a meromorphic function, $T^{12 \leftrightarrow 34}(\omega, z)$ must vanish as $\omega \rightarrow \pm\infty$, i.e. $T^{12 \leftrightarrow 34}(\omega, z)$ behavior asymptotically as (32) for $p < 0$. In general, such an asymptotic behavior does not hold when ω approaches complex infinity, i.e. $\omega \rightarrow \infty \times e^{i\theta}$ for $\theta \neq 0, \pi$.

We will assume that the asymptotic behaviors in (32), which is defined for real ω , can be extended for a small range of $\arg \omega$. More precisely, we impose the following assumption on $T^{12 \leftrightarrow 34}(\omega)$:

³Here and throughout this paper, we assume that β is real when taking the imaginary part of $\Psi(\beta, z)$.

Boundedness: $T^{12\leftrightarrow 34}(\omega, z)$ is bounded for some finite extension onto the the complex ω , i.e. $T^{12\leftrightarrow 34}(\omega, z) \rightarrow 0$ as $|\omega| \rightarrow \infty$ with the argument

$$\arg \omega \in \left(-\theta_c^{12\leftrightarrow 34}, \theta_c^{12\leftrightarrow 34} \right) \cup \left(\pi - \theta_c^{12\leftrightarrow 34}, \pi + \theta_c^{12\leftrightarrow 34} \right), \quad (39)$$

with a finite angle $\theta_c^{12\leftrightarrow 34}$ that in general depends on z .

This assumption, while not rigorously proven here, can be argued from the fact that the amplitude is analytic in the complex plane except for the real and imaginary axes. Thus the convergence property can only change smoothly as we move away from the axes. Thus we expect that there always exists a finite neighborhood where T remain convergent. As we will see, in the case of open and closed string amplitudes, θ_c 's are in general finite and non-vanishing.

Let us exam the analytic structure of the amplitude $T^{12\leftrightarrow 34}(\omega, z)$ on the complex ω -plane. By the bulk-locality, the exchange of single-particle states (of masses m_i) leads to s -channel poles located slight below or above the real axes (at $\omega = \pm m_i \pm i\epsilon$) due to Feynman $i\epsilon$. At the loop level, the exchange of multi-particle states lead to branch cuts located slight below or above the real axes. The crossing images of the s -channel poles are the t - and u -channel poles (at $\omega = \pm i\sqrt{\frac{z}{z-1}}m_i$ and $\omega = \pm i\sqrt{z}m_i$). The poles and branch cuts are shown schematically in figure 1. There could be other branch cuts away from the real and the imaginary axes, which do not correspond to the exchange of multi-particle states.⁴ They are not depicted in the figures, as they would not play a role in our later computation. Finally, the branch cut of the $\omega^{\beta-1}$ is chosen to be along the negative real axis, and is also not depicted in the figures.

Consider the fan-like contour displayed in the left of figure 1, with an angle less than θ_c . As the infinity part I_3 vanishes, the absence of poles in the contour imply

$$\Psi(\beta, z) = B(z) \int_{I_1} d\omega \omega^{\beta-1} T(\omega, z) = -B(z) \int_{I_2} d\omega \omega^{\beta-1} T(\omega, z). \quad (40)$$

Now extend the contour symmetrically to the lower half plane, as shown in the right of figure 1. The new contour will then pick up the residue from the $i\epsilon$ prescription of the propagators. Note that since I'_2 is just the reflection of I_2 along the real axes, the two simply have the opposite sign for the real part:

$$\int_{I'_2} d\omega \omega^{\beta-1} T(\omega, z) = -\left[\int_{I_2} d\omega \omega^{\beta-1} T(\omega, z) \right]^*. \quad (41)$$

Furthermore, since the $i\epsilon$ poles are away from the contour I'_2 , and we are free to take the $\epsilon \rightarrow 0$ limit, for which the amplitude $T(\omega, z)$ is a real function of ω , i.e.

$$T(\omega, z)^* = T(\omega^*, z). \quad (42)$$

Again since the integration along I'_3 vanishes, the imaginary part of $\Psi(\beta, z)$ is now simply given by the poles and branch cuts from the $i\epsilon$ prescription

$$\begin{aligned} \text{Im} \Psi(\beta, z) &= -\frac{1}{2i} B(z) \int_{I_2+I'_2} d\omega \omega^{\beta-1} T(\omega, z) \\ &= -B(z) \left\{ \pi \sum_i \text{Res}_{\omega \rightarrow m_i} [\omega^{\beta-1} T(\omega, z)] + \int_M^\infty d\omega \omega^{\beta-1} \text{Disc} [T(\omega, z)] \right\}, \end{aligned} \quad (43)$$

where m_i are the position of the factorization poles, and M is the branch point of the branch cuts, which is present due to loop effects.⁵

⁴The branch points of such branch cuts are called the anomalous thresholds.

⁵If the convergent angle θ_0 is great than $\frac{\pi}{2}$ (e.g. massive scalar exchange amplitude), one might worry that

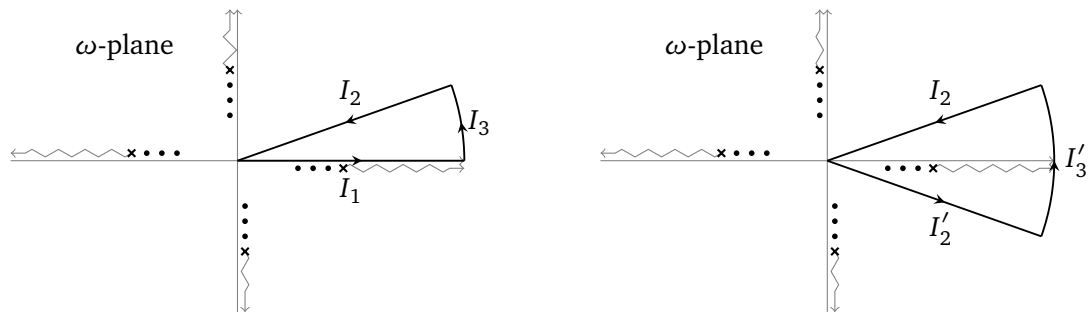

Figure 1: The analytic structure of the amplitude $T(\omega, z)$ on the complex ω plane. The branch cuts associated to the anomalous thresholds are not depicted in the figure, since they are away from the real ω axes, and would not contribute the the contour integrals when the angle between the I_2 and $-I'_2$ segments of the contour is small enough.

In summary, we find that the imaginary part of the celestial amplitude is simply governed by the residue or (massive) discontinuity of the scattering amplitude. For s -channel kinematics, we find that $\text{Im}[\Psi]$ is given by the projection of the s -channel residue or discontinuity onto the celestial sphere as in eq.(43).

3.2 Positivity in $\text{Im}[\Psi(\beta, z)]$

If the external states are arranged as $a, b \rightarrow b, a$, where (a, b) represents potentially distinct species, the residue and the discontinuity are positively expandable on Legendre polynomials for scalars and Jacobi polynomials for spinning states [23]. Thus the imaginary part of the celestial amplitude must be positively expanded on the Mellin-transform of these orthogonal polynomials.

Let us first focus on the case of scalar external states. At the tree-level, the imaginary part of the celestial amplitude only picks up the poles corresponding to the factorization channels. The associated residues in the three kinematic regimes are

$$\begin{aligned}
 12 \rightarrow 34 : \quad \text{Res}_{\omega=m} \left[\omega^{\beta-1} \frac{m^{2J} P_J \left(\frac{u-t}{m^2} \right)}{\omega^2 - m^2} \right] &= \frac{m^{\beta-2+2J}}{2} \cdot P_J \left(\frac{z-2}{z} \right), \\
 13 \rightarrow 24 : \quad \text{Res}_{\omega=m} \left[\omega^{\beta-1} \frac{m^{2J} P_J \left(\frac{s-t}{m^2} \right)}{\omega^2 - m^2} \right] &= \frac{m^{\beta-2+2J}}{2} \cdot P_J(1-2z), \\
 14 \rightarrow 23 : \quad \text{Res}_{\omega=m} \left[\omega^{\beta-1} \frac{m^{2J} P_J \left(\frac{u-s}{m^2} \right)}{\omega^2 - m^2} \right] &= \frac{m^{\beta-2+2J}}{2} \cdot P_J \left(\frac{z+1}{z-1} \right).
 \end{aligned} \tag{44}$$

Note that we have written the argument of the Legendre polynomials in terms of Mandelstam invariants in such a way that manifest the exchange symmetry in each channel. Thus from (43) the imaginary part of the scalar celestial amplitude must be positively expanded on the

there will be poles coming from other channel contributing to the imaginary part in (43). In fact, because other channel poles are lying on the pure imaginary axis, and they are coming in pair. One can easily verify total residue sum is 0 in the RHS contour of fig. 1. Thus the result is not changed even if the $\theta_0 > \pi/2$ is bigger than $\pi/2$

following basis

$$\begin{aligned}
 \mathbf{Im} \Psi^{12 \leftrightarrow 34}(\beta, z) &= \pi z^2 \sum_a p_a P_{J_a} \left(\frac{z-2}{z} \right), & (z \geq 1), \\
 \mathbf{Im} \Psi^{13 \leftrightarrow 24}(\beta, z) &= \pi z^{\frac{\beta}{2}+2} \sum_a p_a P_{J_a} (1-2z), & (1 \geq z \geq 0), \\
 \mathbf{Im} \Psi^{14 \leftrightarrow 23}(\beta, z) &= \pi (-z)^{\frac{\beta}{2}+2} (1-z)^{-\frac{\beta}{2}} \sum_a p_a P_{J_a} \left(\frac{z+1}{z-1} \right), & (0 \geq z),
 \end{aligned} \tag{45}$$

where $p_a = g_a^2 \left(\frac{m_a}{2}\right)^{\beta-3} m_a^{2J_a+1}$, and the index a labels a state with quantum numbers (m_a, J_a) coupling to the massless external states with strength g_a . While we have set up the equations for tree-level exchanges, extension to massive loops is straight forwards since the discontinuity along the branch cut also have a positive partial wave expansion. Thus for massive loops, we only need to change the discrete sum into a continuous integration. For example

$$\sum_a p_a P_{J_a} \left(\frac{z-2}{z} \right) \rightarrow \int_{M^2} dm^2 p_J(m^2) P_{J_a} \left(\frac{z-2}{z} \right), \tag{46}$$

where M^2 denotes the beginning of the branch cut. This difference does not change our analysis, and thus for brevity from now on we will not make a distinction between the discrete sum and continuous integration.

Extension to spinning external states is straight forward. On the factorization pole, the residue polynomial is now:

$$T_{\ell_i}(s, t)|_{s \rightarrow m^2} = - \frac{m^{2J} d_{\ell_{34}, \ell_{12}}^J \left(\arccos\left(\frac{u-t}{m^2}\right) \right)}{s - m^2 + i\epsilon}, \tag{47}$$

where $\ell_{ij \pm kl} = (\ell_i - \ell_j) \pm (\ell_k - \ell_l)$, and $d_{\ell_{34}, \ell_{12}}^J(\phi)$ is the Wigner (small) d -matrix which can be conveniently given in Jacobi polynomials,

$$d_{\ell_{34}, \ell_{12}}^J(\phi) = B_{12;34}^J \left(\sin \frac{\phi}{2} \right)^{\ell_{12}-34} \left(\cos \frac{\phi}{2} \right)^{\ell_{12}+34} \mathcal{J}_{J-\ell_{12}}^{\ell_{12}-34, \ell_{12}+34}(\cos \phi), \tag{48}$$

where $\mathcal{J}_n^{\alpha, \beta}$ is the Jacobi polynomial and the constant $B_{i_1 i_2; i_3 i_4}^J \equiv \sqrt{\frac{(J+\ell_{i_1 i_2})!(J-\ell_{i_1 i_2})!}{(J+\ell_{i_3 i_4})!(J-\ell_{i_3 i_4})!}}$. This gives the following representation of the imaginary part $\mathbf{Im}[\Psi(\beta, z)]$ in the three different regions (25) on the equator:

$$\begin{aligned}
 \mathbf{Im} \Psi^{12 \leftrightarrow 34}(\beta, z) &= \sum_i p_{i12;34} z^{2-\ell_{12}} (z-1)^{\frac{\ell_{12}-34}{2}} \mathcal{J}_{J-\ell_{12}}^{\ell_{12}-34, \ell_{12}+34} \left(\frac{z-2}{z} \right) & (z \geq 1), \\
 \mathbf{Im} \Psi^{13 \leftrightarrow 24}(\beta, z) &= \sum_i p_{i13;24} z^{\frac{\beta+\ell_{13}+24}{2}+2} (1-z)^{\frac{\ell_{13}-24}{2}} \mathcal{J}_{J-\ell_{13}}^{\ell_{13}+24, \ell_{13}-24} (1-2z) & (1 \geq z \geq 0), \\
 \mathbf{Im} \Psi^{14 \leftrightarrow 23}(\beta, z) &= \sum_i p_{i14;23} \frac{(-z)^{\frac{\beta+\ell_{14}+23}{2}+2}}{(1-z)^{\frac{\beta}{2}+\ell_{23}}} \mathcal{J}_{J-\ell_{23}}^{\ell_{14}+23, \ell_{14}-23} \left(\frac{z+1}{z-1} \right) & (0 \geq z),
 \end{aligned} \tag{49}$$

where $p_{i12;34} = \pi g_i \left(\frac{m}{2}\right)^{\beta-3} m_i^{2J_i+1} B_{12;34}^{J_i} > 0$. Indeed setting $\ell_i = 0$ in (49) one recovers the scalar basis in (45). The coefficient g_i becomes positive if the external states are arranged as $\ell_3 = -\ell_2$ and $\ell_4 = -\ell_1$, i.e. such that the configuration corresponds to forward scattering.

Thus for each kinematics, $\mathbf{Im} \Psi$ has a positive expansion on the basis in eq.(49). Note that the fact that the Wigner d -matrix serves as an expansion basis for the flat-space amplitude is a reflection of factorization and Poincaré symmetry. Since the basis functions in eq.(49) is simply the projection of the Wigner d -matrix, they must be intimately tied to the "image" of Poincaré symmetry on the celestial sphere. Indeed, in the following, we will find that these are precisely the Poincaré partial waves introduced in [20].

3.3 Poincaré partial wave expansion

Let us first review the Poincaré partial waves introduced in [20], focusing on the celestial amplitude in the $12 \leftrightarrow 34$ kinematics. It can be written as an inner product between the in and out states

$$\tilde{\mathcal{A}}_{\Delta_i, \ell_i}^{12 \leftrightarrow 34}(z_i, \bar{z}_i) = \langle \Delta_3, z_3, \bar{z}_3, \ell_3, \Delta_4, z_4, \bar{z}_4, \ell_4 | \Delta_1, z_1, \bar{z}_1, \ell_1, \Delta_2, z_2, \bar{z}_2, \ell_2 \rangle. \quad (50)$$

The Hilbert space can be decomposed into irreducible unitary representations of the Poincaré algebra. According to Wigner’s classification, they are the massive representations labeled by the mass m and spin J , and the massless representations labeled by the helicity ℓ . Consider the projectors

$$\begin{aligned} \mathbb{P}_{m,J} &= \frac{1}{2J+1} \sum_{J_3=-J}^J |m, J, J_3\rangle \langle m, J, J_3|, \\ \mathbb{P}_\ell &= \frac{1}{2} \sum_{\epsilon=\pm} |\epsilon \ell\rangle \langle \epsilon \ell|, \end{aligned} \quad (51)$$

which project onto a single massive or massless representation. The projectors $\mathbb{P}_{m,J}$ and \mathbb{P}_ℓ commute with the Poincaré generators P^μ and $M^{\mu\nu}$, i.e.

$$[P^\mu, \mathbb{P}_{m,J}] = 0 = [M^{\mu\nu}, \mathbb{P}_{m,J}], \quad (52)$$

and similarly for the massless projector \mathbb{P}_ℓ . The massive and massless Poincaré partial waves are defined by inserting the projectors into the inner product (50),

$$\begin{aligned} \tilde{\mathcal{A}}_{\Delta_i, \ell_i; m, J}^{12 \leftrightarrow 34}(z_i, \bar{z}_i) &= \langle \Delta_3, z_3, \bar{z}_3, \ell_3, \Delta_4, z_4, \bar{z}_4, \ell_4 | \mathbb{P}_{m,J} | \Delta_1, z_1, \bar{z}_1, \ell_1, \Delta_2, z_2, \bar{z}_2, \ell_2 \rangle, \\ \tilde{\mathcal{A}}_{\Delta_i, \ell_i; \ell}^{12 \leftrightarrow 34}(z_i, \bar{z}_i) &= \langle \Delta_3, z_3, \bar{z}_3, \ell_3, \Delta_4, z_4, \bar{z}_4, \ell_4 | \mathbb{P}_\ell | \Delta_1, z_1, \bar{z}_1, \ell_1, \Delta_2, z_2, \bar{z}_2, \ell_2 \rangle. \end{aligned} \quad (53)$$

The translation and Lorentz generators P^μ and $M^{\mu\nu}$ act on the massless single particle states as differential operators \mathcal{P}^μ and $\mathcal{M}^{\mu\nu}$ given explicitly in [12], which we list in Appendix B. By (52), the Poincaré partial waves satisfy the constraints

$$\begin{aligned} (\mathcal{P}_1^\mu + \mathcal{P}_2^\mu - \mathcal{P}_3^\mu - \mathcal{P}_4^\mu) \tilde{\mathcal{A}}_{\Delta_i, \ell_i; m, J}^{12 \leftrightarrow 34}(z_i, \bar{z}_i) &= 0, \\ (\mathcal{M}_1^{\mu\nu} + \mathcal{M}_2^{\mu\nu} + \mathcal{M}_3^{\mu\nu} + \mathcal{M}_4^{\mu\nu}) \tilde{\mathcal{A}}_{\Delta_i, \ell_i; m, J}^{12 \leftrightarrow 34}(z_i, \bar{z}_i) &= 0, \end{aligned} \quad (54)$$

and similar for the massless Poincaré partial waves. Since the above constraints are the same constraints used in [17] to derive the form in (16) and (18) of the celestial amplitude, the Poincaré partial waves should also take the form as (16) and (18).

Beside (54), the Poincaré partial waves satisfy additional differential equations given by the Casimir operators of the Poincaré algebra. The Poincaré algebra has a quadratic and a quartic Casimir operators

$$P_\mu P^\mu, \quad W_\mu W^\mu, \quad (55)$$

where $W^\mu = \frac{1}{2} \epsilon^{\mu\nu\rho\sigma} M_{\nu\rho} P_\sigma$ is the Pauli-Lubanski pseudo-vector. The two Casimir operators have eigenvalues $-m^2$ and $m^2 J(J+1)$ when acting on a state with mass m and spin J , i.e.

$$\begin{aligned} P_\mu P^\mu |m, J, J_3\rangle &= -m^2 |m, J, J_3\rangle, \\ W_\mu W^\mu |m, J, J_3\rangle &= m^2 J(J+1) |m, J, J_3\rangle. \end{aligned} \quad (56)$$

By inserting the Casimir operator $P^\mu P_\mu$ into the inner product form of the Poincaré partial wave $\tilde{\mathcal{A}}_{\Delta_i, \ell_i; m, J}^{12 \leftrightarrow 34}(z_i, \bar{z}_i)$, and using the formulae (120) and (122), one finds a differential equation

$$\begin{aligned} (\mathcal{P}_1 + \mathcal{P}_2)^\mu (\mathcal{P}_1 + \mathcal{P}_2)_\mu \tilde{\mathcal{A}}_{\Delta_i, \ell_i; m, J}^{12 \leftrightarrow 34}(z_i, \bar{z}_i) &= \langle \Delta_3, z_3, \bar{z}_3, \ell_3, \Delta_4, z_4, \bar{z}_4, \ell_4 | \mathbb{P}_{m,J} P^\mu P_\mu | \Delta_1, z_1, \bar{z}_1, \ell_1, \Delta_2, z_2, \bar{z}_2, \ell_2 \rangle \\ &= -m^2 \tilde{\mathcal{A}}_{\Delta_i, \ell_i; m, J}^{12 \leftrightarrow 34}(z_i, \bar{z}_i). \end{aligned} \quad (57)$$

Similarly, the Casimir operator $W^\mu W_\mu$ leads to another differential equation

$$(\mathcal{W}_1 + \mathcal{W}_2)^\mu (\mathcal{W}_1 + \mathcal{W}_2)_\mu \tilde{\mathcal{A}}_{\Delta_i, \ell_i; m, J}^{12 \leftrightarrow 34}(z_i, \bar{z}_i) = m^2 J(J+1) \tilde{\mathcal{A}}_{\Delta_i, \ell_i; m, J}^{12 \leftrightarrow 34}(z_i, \bar{z}_i), \quad (58)$$

where $\mathcal{W}^\mu = \frac{1}{2} \epsilon^{\mu\nu\rho\sigma} \mathcal{M}_{\nu\rho} \mathcal{P}_\sigma$. Factoring out some conformal factors similar to (16) and (18) as

$$\begin{aligned} \tilde{\mathcal{A}}_{\Delta_i, \ell_i; m, J}^{12 \leftrightarrow 34}(z_i, \bar{z}_i) &= \frac{\left(\frac{z_{14}}{z_{13}}\right)^{h_3-h_4} \left(\frac{z_{24}}{z_{14}}\right)^{h_1-h_2} \left(\frac{\bar{z}_{14}}{\bar{z}_{13}}\right)^{\bar{h}_3-\bar{h}_4} \left(\frac{\bar{z}_{24}}{\bar{z}_{14}}\right)^{\bar{h}_1-\bar{h}_2}}{z_{12}^{h_1+h_2} z_{34}^{h_3+h_4} \bar{z}_{12}^{\bar{h}_1+\bar{h}_2} \bar{z}_{34}^{\bar{h}_3+\bar{h}_4}} \\ &\times (z-1)^{\frac{\Delta_1-\Delta_2-\Delta_3+\Delta_4}{2}} \delta(iz-i\bar{z}) \Phi_{m, J}^{12 \leftrightarrow 34}(\Delta, \ell_i, z), \end{aligned} \quad (59)$$

(57) reduces to the differential equation on the total dimension Δ and the cross ratio z

$$-4e^{2\partial_\Delta} \Phi_{m, J}^{12 \leftrightarrow 34}(\Delta, \ell_i, z) = -m^2 \Phi_{m, J}^{12 \leftrightarrow 34}(\Delta, \ell_i, z). \quad (60)$$

Similarly, (58) gives the differential equation

$$\begin{aligned} &\left[\frac{(\frac{1}{4} \ell_{12+34}^2 - 4)z^2 + (10 - \ell_{12} \ell_{34})z - 6}{z-1} + (3z-4)z\partial - (z-1)z^2\partial^2 \right] \Phi_{m, J}^{12 \leftrightarrow 34}(\Delta, \ell_i, z) \\ &= J(J+1) \Phi_{m, J}^{12 \leftrightarrow 34}(\Delta, \ell_i, z). \end{aligned} \quad (61)$$

Let us briefly comment on the Casimir equations for the massless Poincaré partial waves. By the same derivation, we find the Casimir operator $P^\mu P_\mu$ gives the differential equation (60) with $m^2 = 0$. However, the differential operator on the right hand side of (60) is invertible. Hence, the massless Poincaré partial waves should be zero identically.

One could repeat the above analysis for the celestial amplitude in the $13 \leftrightarrow 24$ and $14 \leftrightarrow 23$ kinematics, and derive the corresponding differential equations for the Poincaré partial waves $\Phi_{m, J}^{13 \leftrightarrow 24}(\Delta, \ell_i, z)$ and $\Phi_{m, J}^{14 \leftrightarrow 23}(\Delta, \ell_i, z)$. The solutions to the Casimir equations in the three kinematics (25) are (again $\beta = \Delta - 4$)

$$\Phi_{m, J}^{\ell_i}(\beta, z) = \left(\frac{m}{2}\right)^\beta \sqrt{\frac{(2J+1)}{m}} \begin{cases} B_{12, 34}^J z^{2-\ell_{12}} (z-1)^{\frac{\ell_{12}-34}{2}} \mathcal{J}_{J-\ell_{12}}^{\ell_{12+34}, \ell_{12-34}}\left(\frac{z-2}{z}\right) & (z \geq 1), \\ B_{13, 24}^J z^{\frac{\beta+\ell_{13+24}}{2}+2} (1-z)^{\frac{\ell_{13-24}}{2}} \mathcal{J}_{J-\ell_{13}}^{\ell_{13+24}, \ell_{13-24}}(1-2z) & (1 \geq z \geq 0), \\ B_{14, 23}^J \frac{(-z)^{\frac{\beta+\ell_{14+23}}{2}+2}}{(1-z)^{\frac{\beta}{2}+\ell_{23}}} \mathcal{J}_{J-\ell_{23}}^{\ell_{14+23}, \ell_{14-23}}\left(\frac{z+1}{z-1}\right) & (0 \geq z). \end{cases} \quad (62)$$

One see exactly that the Poincaré partial waves (62) are identical to the expansion basis in (49) in each kinematics threshold up to normalization factors.

Thus combining everything, we conclude that the imaginary part of the celestial amplitude has a positive expansion on the massive Poincaré partial wave, namely,

$$\mathbf{Im} \Psi(\beta, \ell_i, z) = \sum_a p_a \Phi_{m_a, J_a}(\beta, \ell_i, z), \quad p_a > 0. \quad (63)$$

Note that since the Jacobi polynomials are orthogonal polynomials, the Poincaré partial waves also satisfy orthogonality relations [20], and the coefficients p_a are unique. We emphasize that the above is valid for tree-level exchanges and massive internal loops. Once simply do the trivial translation in eq.(46). The generalization to supersymmetric theories is straightforward. Once again the expansion polynomial is given by the projection of the susy-spinning polynomials on to the celestial sphere. These polynomials are again Jacobi polynomials, but with the helicities indicating that of the highest weighted state in a susy multiplet. For details see [24].

Crossing symmetry: Let us consider the implications of crossing symmetry on the celestial amplitude. For a crossing symmetric amplitude, we would expect the three kinematic region of the celestial amplitude to be related to each other. Indeed, we have:

$$\begin{cases} s \leftrightarrow u & \Psi^{13 \leftrightarrow 24}(\beta, z) = z^{\frac{\beta}{2}+4} \Psi^{12 \leftrightarrow 34}(\beta, \frac{1}{z}) & (1 \geq z \geq 0), \\ s \leftrightarrow t & \Psi^{12 \leftrightarrow 34}(\beta, z) = (\frac{z}{1-z})^{\frac{\beta}{2}+2} \Psi^{14 \leftrightarrow 23}(\beta, 1-z) & (z \geq 1), \\ u \leftrightarrow t & \Psi^{13 \leftrightarrow 24}(\beta, z) = (z-1)^2 \Psi^{14 \leftrightarrow 23}(\beta, \frac{z}{z-1}) & (1 \geq z \geq 0), \end{cases} \quad (64)$$

for the celestial amplitude of any permutation invariant theory. Furthermore, since the residue of each channel must respect the exchange symmetry of the legs on one side of the factorization, this implies that the imaginary part of $\Psi(\beta, z)$ must further satisfy the following “self-dual” like identities:

$$\begin{cases} \text{Im} \Psi^{13 \leftrightarrow 24}(\beta, z) = (\frac{z}{1-z})^2 \text{Im} \Psi^{13 \leftrightarrow 24}(\beta, 1-z) & (1 \geq z \geq 0), \\ \text{Im} \Psi^{14 \leftrightarrow 23}(\beta, z) = (-1)^{\frac{\beta}{2}} z^{\frac{3\beta}{2}+4} \text{Im} \Psi^{14 \leftrightarrow 23}(\beta, \frac{1}{z}) & (0 \geq z), \\ \text{Im} \Psi^{12 \leftrightarrow 34}(\beta, z) = (z-1)^2 \text{Im} \Psi^{12 \leftrightarrow 34}(\beta, \frac{z}{z-1}) & (z \geq 1). \end{cases} \quad (65)$$

It is straightforward to verify that the Poincaré partial waves in (62) respect the crossing equations (64) and (65).

4 Open and closed string celestial amplitudes

We have already seen how the imaginary part of the celestial amplitude encodes the information of poles and branch cuts on complex ω plane. Furthermore, as discussed in Section 5, the integrand can be analytic continued to other unphysical z domains. However, the UV convergence of the integral relies on certain regions of ω plane. In this section, we will first use type-I and II superstring amplitudes:⁶

$$\text{type-I: } \frac{\Gamma[-s]\Gamma[-t]}{\Gamma[1+u]}, \quad \text{type-II: } \frac{\Gamma[-s]\Gamma[-t]\Gamma[-u]}{\Gamma[1+s]\Gamma[1+u]\Gamma[1+t]}, \quad (66)$$

as examples to determine the convergent regions on ω plane for all z dependence. As indicated in Figure 2, they are in general z -dependent for open strings while enjoys z -independent for closed strings. Then we will discuss how bulk-locality encoded in the imaginary part of tree-level celestial string amplitude in physical z domains. Finally, when we discuss the celestial dispersion relation in Section 6 we will verify those relations with celestial string amplitudes in Section 6.1.

4.1 Convergent regions in string theory

As is widely known, in the fixed-angle scatterings, string amplitudes are expected to decay exponentially at large real ω . However, the suppression is in general not true in the whole complex ω plane. Therefore in this sub-section we will study this problem for open and closed string amplitudes. Writing $\omega = r e^{i\theta}$, the $r \rightarrow \infty$ limit of string amplitudes behave as:

$$T(r^2 e^{2i\theta}, z) \sim \exp\left[g(\theta, z)r^2 + \mathcal{O}(\log r)\right]. \quad (67)$$

Hence, for given z , the amplitude is suppressed in the limit $r \rightarrow \infty$ when

$$\text{Re}[g(\theta, z)] < 0, \quad (68)$$

⁶Here we have neglected the F^4 and R^4 pre-factor for simplicity. Their effect can be incorporated straightforwardly.

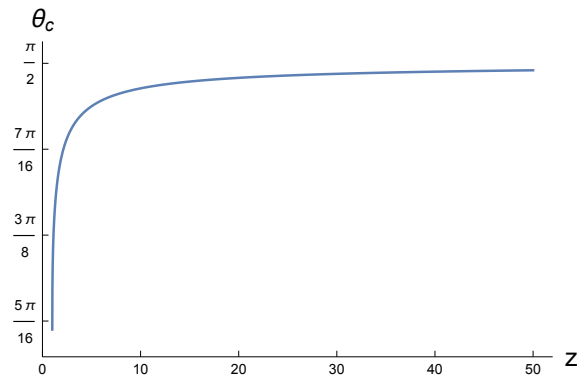

Figure 2: The angle θ_c for the open string amplitude in the $12 \leftrightarrow 34$ kinematics as a function of z .

which, as one will see, gives the convergent region

$$\theta \in (-\theta_c, \theta_c) \cup (\pi - \theta_c, \pi + \theta_c), \tag{69}$$

where the angle θ_c is the root of $\text{Re}[g(\theta, z)] = 0$ when $\theta \in (0, \frac{\pi}{2})$. Let us consider the open and closed string separately,

- **Open string**

The gluon amplitude in the type-I superstring theory is

$$T_{\text{open}}(s, u) = \frac{\Gamma(-s)\Gamma(-t)}{\Gamma(1-s-t)}. \tag{70}$$

In the $12 \rightarrow 34$ kinematic region ($z > 1$), and restricting to $\theta \in (0, \frac{\pi}{2})$, we have

$$g(\theta, z) = e^{2i\theta} \frac{[(z-1)(\log(z-1)+i\pi)-z \log(z)]}{z}. \tag{71}$$

The inequality (68) gives the following equation for the angle θ_c ,

$$\cot(2\theta_c) = \frac{\pi(1-z)}{z \log z - (z-1) \log(z-1)}. \tag{72}$$

The angle θ_c as a function of z is plotted in figure 2. One can see that starting from $z = 1$, the angle θ_c is gradually increasing from $\frac{\pi}{4}$ to $\frac{\pi}{2}$ as $z \rightarrow \infty$.

Also one can perform the same analysis for general angle $\theta \in (-\pi, \pi)$, and find that the convergent regions in the other quadrants are also specified by the same angle θ_c and given by (69). One can further repeat the same analysis for the other kinematics $13 \leftrightarrow 24$ and $14 \leftrightarrow 23$. The results are summarized in Table 2.

Table 2: Characteristic angles in open string.

$\theta_c^{12 \leftrightarrow 34}(z) \quad (z \geq 1)$	$\theta_c^{13 \leftrightarrow 24}(z) \quad (1 \geq z \geq 0)$	$\theta_c^{14 \leftrightarrow 23}(z) \quad (0 \geq z)$
$\frac{1}{2} \cot^{-1} \left[\frac{\pi(1-z)}{z \log z - (z-1) \log(z-1)} \right]$	$\frac{\pi}{4}$	$\frac{1}{2} \cot^{-1} \left[\frac{\pi z}{(1-z) \log(1-z) + z \log(-z)} \right]$

- **Closed string**

The graviton amplitude in the type-II superstring is

$$T_{\text{closed}}(s, u) = \frac{\Gamma(-s)\Gamma(-t)\Gamma(-u)}{\Gamma(1+s)\Gamma(1+t)\Gamma(1+u)}. \tag{73}$$

It turns out that the large r behavior of the closed string amplitude is much simpler than the open string case. In the $12 \leftrightarrow 34$ kinematic region ($z \geq 1$), we find

$$g(\theta, z) = 2e^{2i\theta} \frac{(z-1)\log(z-1) - z \log z}{z}, \quad (0 < \theta < \pi/2). \quad (74)$$

The condition for the real part to be negative is

$$\cos(2\theta) > 0 \Rightarrow 0 < \theta < \frac{\pi}{4}. \quad (75)$$

We can repeat the same analysis for general angle $\theta \in (-\pi, \pi)$ and for the other kinematics $13 \leftrightarrow 24$ and $14 \leftrightarrow 23$. The convergent regions for all cases are given by (69) with the angle θ_c equals to $\frac{\pi}{4}$.

4.2 $\text{Im} \Psi(\beta, z)$ in string theory

Taking $\beta \in \mathbb{R}$, from (43), $\text{Im} \Psi(\beta, z)$ is given as a sum of the residues of the poles (and also an integral of the discontinuity) near the positive real axis. For both open and closed string amplitudes, the poles near the positive real axis are located at $\omega = \sqrt{n}$ for $n \in \mathbb{Z}_{>0}$, and we have

$$\text{Im} \Psi(\beta, z) = -\pi B(z) \sum_{n=1}^{\infty} (\sqrt{n})^{\beta-1} \text{Res}_{\omega_n=\sqrt{n}} [T(\omega_n, z)] \quad (\beta > \beta_*) \quad (76)$$

In the following, we will verify this formula by directly comparing the truncated sum with the numerical result of the Mellin integration:

- **Open String**

The massive poles of the open string amplitude (70) are located at $s, t = 1, 2, \dots, n$. And the corresponding residues for s -channel are,

$$\text{Res}_{s=n} [T_{\text{open}}(s, t)] = \frac{\prod_{k=1}^{n-1} (t+k)}{n!} \quad (77)$$

The residues of the t -channel poles are given by exchanging s with t . Now we can compute $\text{Im} \Psi(\beta, z)$. In $12 \rightarrow 34$ kinematic region, using eq.(43), the imaginary part will only receive contribution from s -channel massive poles located on the positive- ω axis at $\omega_n = \sqrt{n}$ with the residue

$$\text{Res}_{\omega=\sqrt{n}} [T_{\text{open}}^{12 \rightarrow 34}(\omega^2, -\frac{1}{z}\omega^2)] = \frac{[n(\frac{1}{z}-1)+1]_{n-1}}{2\sqrt{n}n!} \quad (78)$$

Thus, the imaginary part of the open string celestial amplitude is

$$\begin{aligned} \text{Im} \Psi_{\text{open}}^{12 \leftrightarrow 34}(\beta, z) &= -\pi B^{12 \rightarrow 34}(z) \sum_{n=1}^{\infty} (\sqrt{n})^{\beta-1} \text{Res}_{\omega=\sqrt{n}} [T_{\text{open}}^{12 \rightarrow 34}(\omega^2, -\frac{1}{z}\omega^2)] \\ &= -\pi 2^{3-\beta} z^2 \sum_{n=1}^{\infty} (\sqrt{n})^{\beta-2} \frac{[n(\frac{1}{z}-1)+1]_{n-1}}{2n!} \quad (z > 1). \end{aligned} \quad (79)$$

One can perform the same computation for $14 \rightarrow 23$, the result is,

$$\begin{aligned} \text{Im} \Psi_{\text{open}}^{14 \leftrightarrow 23}(\beta, z) &= -\pi B^{14 \rightarrow 23}(z) \sum_{n=1}^{\infty} (\sqrt{n})^{\beta-1} \text{Res}_{\omega=\sqrt{n}} [T_{\text{open}}^{14 \rightarrow 23}(\frac{z}{1-z}\omega^2, -\frac{1}{z-1}\omega^2)] \\ &= -\pi 2^{3-\beta} (-z)^{\frac{\beta}{2}+2} (1-z)^{-\frac{\beta}{2}} \sum_{n=1}^{\infty} (\sqrt{n})^{\beta-2} \frac{(\frac{nz}{1-z}+1)_{n-1}}{2n!} \quad (z < 0). \end{aligned} \quad (80)$$

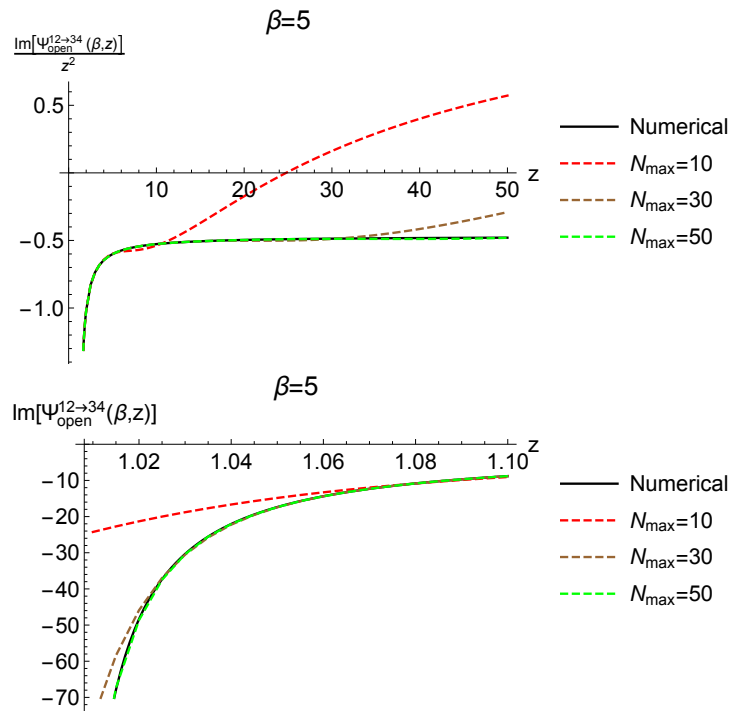

Figure 3: Here we present the comparison of numerical evaluation of Mellin integral and residue sum formula eq.(79) for the imaginary part of celestial open string amplitude. LHS and RHS shows the behavior of $\text{Im} \Psi_{\text{open}}^{12 \leftrightarrow 24}(\beta, z)$ in $z \rightarrow \infty$ and $z \rightarrow 1$

Note that $\text{Im} \Psi_{\text{open}}^{13 \leftrightarrow 24}(\beta, z) = 0$ because the open string amplitude $T_{\text{open}}(s, t)$ has no u -channel pole. The comparison of the truncated sum of eq.(79) with the result from the numerical Mellin integral (28) is given in Figure 3. One can see that $\text{Im} \Psi_{\text{open}}^{12 \leftrightarrow 34}(\beta, z)$ diverges in the limits $z \rightarrow \infty$ and $z \rightarrow 1$. The divergent at $z \rightarrow \infty$ is due to the overall prefactor $B^{12 \rightarrow 34}(z) = \pi z^2$, while the divergent at $z \rightarrow 1$ is due to the non-convergence of the residue sum reflecting the massless $1/t$ singularity in that limit. Note that the divergence occurs for positive β . For negative β the imaginary part is finite as we will see in Section 6.2.

• **Closed String**

In the closed string case, the residues at $s = 1, 2, \dots, n$ are

$$\text{Res}_{s=n}[T_{\text{closed}}(s, t)] = \frac{\prod_{k=1}^{n-1} (t+k)^2}{(n!)^2}. \tag{81}$$

Again, let us focus on the $12 \leftrightarrow 34$ kinematics and the region $z \geq 1$. Using eq.(43), the residue of the pole at $\omega = \sqrt{n}$ is

$$\text{Res}_{\omega=\sqrt{n}} \left[T_{\text{closed}}(\omega^2, \frac{1-z}{z} \omega^2) \right] = \frac{\left[\left(1 + \frac{1-z}{z} n\right)_{n-1} \right]^2}{2\sqrt{n}n(n!)^2}. \tag{82}$$

Thus, the imaginary part of the massive contribution is given by

$$\text{Im} \Psi_{\text{closed}}^{12 \leftrightarrow 34}(\beta, z) = -\pi 2^{3-\beta} z^2 \sum_{n=1}^{\infty} \frac{(\sqrt{n})^{\beta-2}}{2} \left(\frac{\left[n \left(\frac{1}{z} - 1 \right) + 1 \right]_{n-1}}{n!} \right)^2. \tag{83}$$

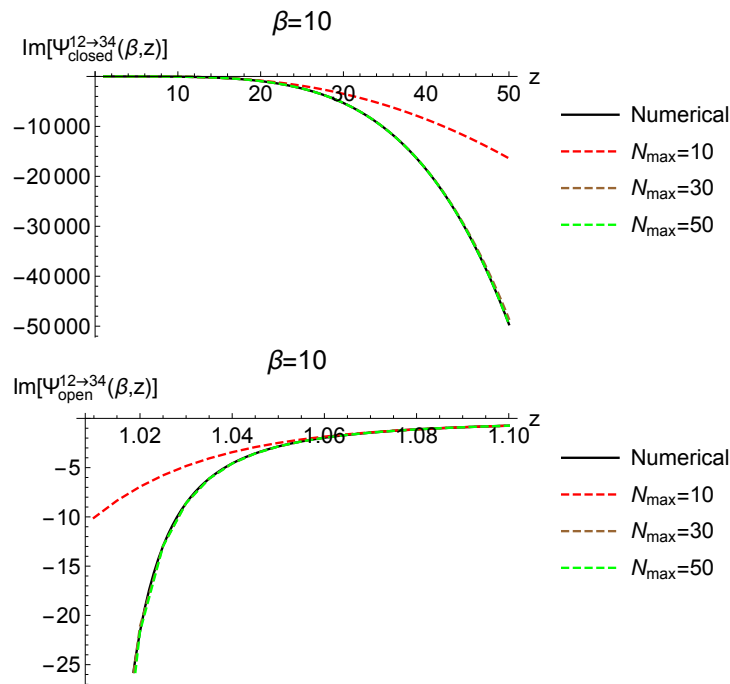

Figure 4: Here we present the comparison of numerical evaluation of Mellin integral and residue sum formula eq.(83) for the imaginary part of celestial closed string amplitude. LHS and RHS shows the behavior of $\text{Im} \Psi_{\text{closed}}^{12 \leftrightarrow 24}(\beta, z)$ in $z \rightarrow \infty$ and $z \rightarrow 1$

The comparison with result from the numerical integral is given in figure 4. Similar with the open string, the divergences in the $z \rightarrow 1$ and $z \rightarrow \infty$ limits are implied by the massless t, u poles.

Using the crossing symmetry, we find the closed string celestial amplitudes for the other two kinematics

$$\begin{aligned} \text{Im} \Psi_{\text{closed}}^{13 \leftrightarrow 24}(\beta, z) &= -\pi 2^{3-\beta} z^{\frac{\beta}{2}+2} \sum_{n=1}^{\infty} \frac{(\sqrt{n})^{\beta-2}}{2} \left[\frac{\left(\frac{n}{z-1} + 1\right)_{n-1}}{n!} \right]^2, \\ \text{Im} \Psi_{\text{closed}}^{14 \leftrightarrow 23}(\beta, z) &= -\pi 2^{3-\beta} (-z)^{\frac{\beta}{2}+2} (1-z)^{-\frac{\beta}{2}} \sum_{n=1}^{\infty} \frac{(\sqrt{n})^{\beta-2}}{2} \left[\frac{\left(\frac{nz}{1-z} + 1\right)_{n-1}}{n!} \right]^2. \end{aligned} \tag{84}$$

5 Analytic continuation in z

As reviewed in sec.2, the celestial four-point amplitude consists of three different functions defined in three distinct regions on the real circle of the complex sphere. One can ask if the three functions can be analytically connected to each other. Consider the simple massive scalar exchange example, and compare eq.(37) with

$$\begin{aligned} \Psi^{13 \leftrightarrow 24}(\beta, z) &= \frac{\pi g^2}{\sin \frac{\pi \beta}{2}} \left(\frac{m}{2}\right)^{\beta-2} z^2 \left[1 + e^{\frac{1}{2} \pi i \beta} z^{\frac{\beta}{2}} + \left(\frac{z}{1-z}\right)^{\frac{\beta}{2}} \right] \quad (1 \geq z \geq 0), \\ \Psi^{14 \leftrightarrow 23}(\beta, z) &= \frac{\pi g^2}{\sin \frac{\pi \beta}{2}} \left(\frac{m}{2}\right)^{\beta-2} z^2 \left[1 + (-z)^{\frac{\beta}{2}} + e^{\frac{1}{2} \pi i \beta} \left(\frac{-z}{1-z}\right)^{\frac{\beta}{2}} \right] \quad (0 \geq z). \end{aligned} \tag{85}$$

It is straight forward to see that the functions cannot be analytically related.

There are, however, reasons we might want to consider the analytic continuation of a celestial amplitude from the physical region as specified in Table 1 to the unphysical ones. Recall that the presence of bulk factorization is imprinted in the imaginary part of of celestial sphere, where in each kinematic region only the channel with the physical threshold is projected. Thus for fixed z , to access the information of all factorization channels through the imaginary part, we will need to analytic continue Ψ of other kinematic configurations to their unphysical regions. Such analytic continuation will be important when we consider dispersion relations for the celestial amplitude in Section 6.

5.1 The scalar example

Before turning to the general analysis, we will use the massive scalar exchange example to illustrate the last point. To continue $\Psi_{\text{scalar}}^{12\leftrightarrow 34}(\beta, z)$ outside the physical region $z > 1$, we need to be careful about potential monodromies as we continue across the boundaries at $z = 1$ and $z = \infty$. Continuing across $z = 1$ by $z - 1 \rightarrow e^{-\pi i}(1 - z)$ and across $z = \infty$ by $z \rightarrow e^{\pi i}(-z)$, we obtain

$$\Psi_{\text{scalar}}^{12\leftrightarrow 34}(\beta, z) = \frac{\pi g^2}{\sin \frac{\pi\beta}{2}} \left(\frac{m}{2}\right)^{\beta-2} z^2 \begin{cases} e^{\frac{1}{2}\pi i\beta} + z^{\frac{\beta}{2}} + e^{\frac{1}{2}\pi i\beta} \left(\frac{z}{1-z}\right)^{\frac{\beta}{2}} & (1 > z > 0), \\ e^{\frac{1}{2}\pi i\beta} + e^{\frac{1}{2}\pi i\beta} (-z)^{\frac{\beta}{2}} + \left(\frac{z}{z-1}\right)^{\frac{\beta}{2}} & (0 > z). \end{cases} \quad (86)$$

The imaginary part of $\Psi_{\text{scalar}}^{12\leftrightarrow 34}(\beta, z)$ in the new (unphysical) regions are

$$\begin{aligned} \text{Im} \Psi_{\text{scalar}}^{12\leftrightarrow 34}(\beta, z) &= \pi g^2 \left(\frac{m}{2}\right)^{\beta-2} z^2 \begin{cases} 1 + \left(\frac{z}{1-z}\right)^{\frac{\beta}{2}} & (1 > z > 0), \\ 1 + (-z)^{\frac{\beta}{2}} & (0 > z), \end{cases} \\ &= 2^{3-\beta} \pi z^2 g^2 \begin{cases} \text{Res}_{\omega \rightarrow m, \sqrt{\frac{z}{1-z}}m} \left[\omega^{\beta-1} T_{\text{scalar}}^{12\leftrightarrow 34}(\omega, z) \right] & (1 > z > 0), \\ \text{Res}_{\omega \rightarrow m, \sqrt{-z}m} \left[\omega^{\beta-1} T_{\text{scalar}}^{12\leftrightarrow 34}(\omega, z) \right] & (0 > z). \end{cases} \end{aligned} \quad (87)$$

We see that the analytically continued result receives contribution from the s - and t -channel poles in $1 > z > 0$ (the “ u ”-region), and s - and u -channel poles in $0 > z$ (the “ t ”-region). Note that the analytic continuation prescription here is uniquely fixed by demanding that the analytic continued amplitudes match irrespective of which physical region it originated from. More precisely,

$$\begin{aligned} \Psi_{\text{scalar}}^{13\leftrightarrow 24}(\beta, z) &\propto \Psi_{\text{scalar}}^{14\leftrightarrow 23}(\beta, z) \quad (z > 1), \\ \Psi_{\text{scalar}}^{14\leftrightarrow 23}(\beta, z) &\propto \Psi_{\text{scalar}}^{12\leftrightarrow 34}(\beta, z) \quad (1 > z > 0), \\ \Psi_{\text{scalar}}^{12\leftrightarrow 34}(\beta, z) &\propto \Psi_{\text{scalar}}^{13\leftrightarrow 24}(\beta, z) \quad (0 > z), \end{aligned} \quad (88)$$

where the proportionality coefficients being z -independent phases. Explicit comparison fixes the phase to be $(1, e^{-\frac{1}{2}i\pi\beta}, e^{\frac{1}{2}i\pi\beta})$ respectively.

5.2 General analysis

Having gone through the scalar exercise, we are now ready to consider the continuation for general amplitudes. At the level of the integrand, the analytic continuation on z corresponds to the analytic continuation on the Mandelstam variables from the physical to the “unphysical” kinematic regions, as shown in Table 3:

Table 3: The physical and “unphysical” kinematic regions.

	$12 \leftrightarrow 34$	$13 \leftrightarrow 24$	$14 \leftrightarrow 23$
$z > 1$	$s > 0 > u, t$	$u, t > 0 > s$	$u, t > 0 > s$
$1 > z > 0$	$s, t > 0 > u$	$u > 0 > s, t$	$s, t > 0 > u$
$0 > z$	$s, u > 0 > t$	$s, u > 0 > t$	$t > 0 > s, u$

The physical regions are those that have only one positive Mandelstam, sitting on the diagonal entries. Take $\Psi^{12\leftrightarrow 34}$ as an example. The analytic continuation to unphysical regions in z , say $0 > z$, leads to an unphysical kinematic setup ($s, u > 0 > t$) and is distinct from $\Psi^{14\leftrightarrow 23}$ originated from the physical setup $t > 0 > s, u$. Thus it is natural that the three distinct functions on the equator cannot be analytically continued to each other. On the other hand, continuing $\Psi^{13\leftrightarrow 24}$ and $\Psi^{14\leftrightarrow 23}$ to their common unphysical region, i.e. $z > 1$, do yield the same Mandelstam region ($u, t > 0 > s$) and it is natural to identify their analytic continuation. The precise phase can be read off from known amplitudes. Thus we impose the following conditions on the analytic continued celestial amplitudes

$$\begin{aligned}
 \Psi^{13\leftrightarrow 24}(\beta, z) &= \Psi^{14\leftrightarrow 23}(\beta, z), & (z > 1), \\
 \Psi^{14\leftrightarrow 23}(\beta, z) &= e^{-\frac{1}{2}i\pi\beta} \Psi^{12\leftrightarrow 34}(\beta, z), & (1 > z > 0), \\
 \Psi^{12\leftrightarrow 34}(\beta, z) &= e^{\frac{1}{2}i\pi\beta} \Psi^{13\leftrightarrow 24}(\beta, z), & (0 > z),
 \end{aligned}
 \tag{89}$$

where the phases $e^{\pm\frac{1}{2}i\pi\beta}$ are due to analytic continuing the prefactor $B(\beta, z)$ in (28). These conditions could be viewed as the crossing symmetry for celestial amplitudes.⁷ Indeed they are satisfied by the massive scalar exchange. The above is only valid for massless scalar external states. For massless spinning states, crossing will be more complicated since in general it will be related to different helicity sectors. We leave this to future work.

Note that to analytic continue, we need to ensure that the celestial amplitude exists along the path of continuation. More precisely, the celestial amplitude $\Psi(\beta, z)$ given by the integral of the flat-space amplitude $T(\omega, z)$ must be convergent along the path. As an example, consider continuing $\Psi^{12\leftrightarrow 34}$ from its physical region $z > 1$ to $1 > z > 0$. More explicitly, our path of continuation is given by

$$\begin{aligned}
 P_1 &: \text{from any } z > 1 \text{ to } z = 1 + \epsilon, \\
 P_2 &: z = 1 + \epsilon e^{-i\phi} \text{ for } \phi \text{ from } 0 \text{ to } \pi, \\
 P_3 &: \text{from } z = 1 - \epsilon \text{ to any } z \in (0, 1),
 \end{aligned}
 \tag{90}$$

where $\epsilon > 0$ is a small number. Previously in Section 3.1, we introduced the boundedness condition around (39). For convenience, we restate the condition at here:

$$\lim_{|\omega| \rightarrow 0} T^{12\leftrightarrow 34}(\omega, z) = 0 \quad \text{for } z > 1,
 \tag{91}$$

when

$$\begin{aligned}
 \arg \omega \in \Theta^{12\leftrightarrow 34}(z) \equiv & \left(-\theta_c^{12\leftrightarrow 34}(z), \theta_c^{12\leftrightarrow 34}(z) \right) \\
 & \cup \left(\pi - \theta_c^{12\leftrightarrow 34}(z), \pi + \theta_c^{12\leftrightarrow 34}(z) \right),
 \end{aligned}
 \tag{92}$$

where we have emphasized the z dependence by writing $\theta_c^{12\leftrightarrow 34}(z)$. Now, let us consider the region $1 > z > 0$. Using the identity $T^{12\leftrightarrow 34}(\omega, z) = T^{13\leftrightarrow 24}\left(\frac{i\omega}{\sqrt{z}}, z\right)$, we find that $T^{12\leftrightarrow 34}(\omega, z)$

⁷We thank the anonymous SciPost referee for emphasizing this point.

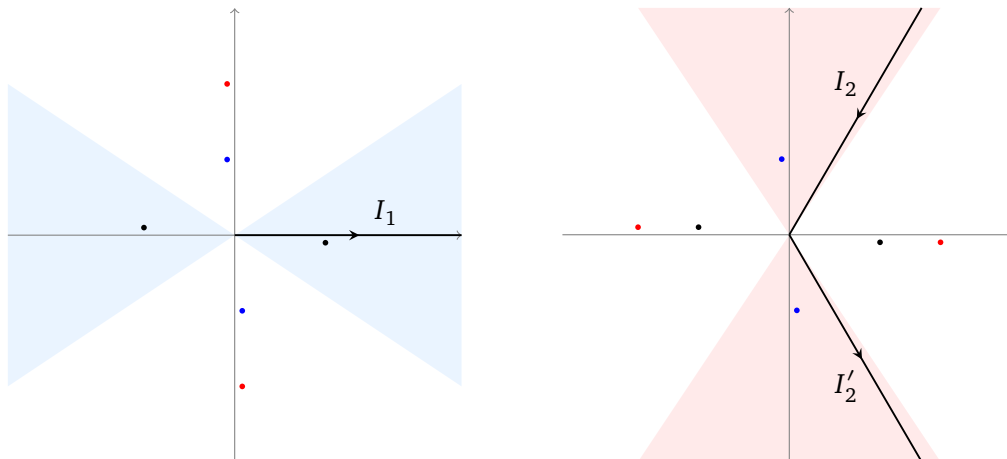

Figure 5: The blue (pink) regions is the convergent angular region $\Theta(z)$ for $z = 1 + \epsilon > 1$ ($z = 1 - \epsilon < 1$). The black, blue or red dot is a representative for the s -, t - or u -channel poles at $\omega = \pm m$, $\omega = \pm i \sqrt{\frac{z}{z-1}} m_i$ or $\omega = \pm i \sqrt{z} m_i$, respectively.

vanishes as $|\omega| \rightarrow \infty$ with the argument

$$\begin{aligned} \arg \omega \in \Theta^{12 \leftrightarrow 34}(z) \equiv & \left(\frac{\pi}{2} - \theta_c^{13 \leftrightarrow 24}(z), \frac{\pi}{2} + \theta_c^{13 \leftrightarrow 24}(z) \right) \\ & \cup \left(-\frac{\pi}{2} - \theta_c^{13 \leftrightarrow 24}(z), -\frac{\pi}{2} + \theta_c^{13 \leftrightarrow 24}(z) \right) \quad \text{for } 1 > z > 0. \end{aligned} \tag{93}$$

In general, the region (93) does not contain the angle $\arg \omega = 0$. Hence, we need to deform the integration contour continuously along the way of the analytic continuation P_2 in (90). For such continuous contour deformation to exist, the convergent region $\Theta(z)$ should exist and continuously move from (92) to (93) when going along the path P_2 . This is illustrated in figure 5, where the region $\Theta(z)$ for $z > 1$ ($1 > z > 0$) is drawn as the blue (pink) region. For the massive scalar exchange the amplitude is convergent for all $\arg \omega \in [0, 2\pi)$, and one do not need to deform the integration contour. For string theory amplitudes, the blue region ($\Theta^{12 \leftrightarrow 34}(z)$ for $z > 1$) is computed in sec.4 and the pink region ($\Theta^{12 \leftrightarrow 34}(z)$ for $1 > z > 0$) can be obtained by the formula (93) using the $\theta_c^{13 \leftrightarrow 24}$ given in Table 2. As we will see in sec.C the convergent region $\Theta(z)$ deforms continuously from the blue to the pink regions when going along the path P_2 .

With this understanding, we can now carry out the analytic continuation. Begin with $\Psi^{12 \leftrightarrow 34}$ in the physical region $z > 1$ defined by the Mellin integral (28), which is an integral along the contour I_1 in figure 5. When going along the path (90), the integration contour should deform accordingly, such that it is always inside the corresponding angular region $\Theta(z)$. When arriving the destination $z \in (0, 1)$, the integration contour becomes $-I_2$ in figure 5. Finally, under the analytic continuation, the t -channel poles (represented by the red dots in figure 5) are rotated from the imaginary axis to the real axis, while the s - and u -channel poles (represented by the black and blue dots in figure 5) remain near the real and the imaginary axes, respectively.

Now, let us consider the imaginary part of the celestial amplitude $\text{Im} \Psi^{12 \leftrightarrow 34}(\beta, z)$ after analytically continuing to $1 > z > 0$. Similar to the discussion in Section 3.1, it can be computed by the integral along the contour $I_2 + I'_2$ as shown in figure 5. However, in this case, we cannot close the contour by adding the I'_3 piece as in figure 1, because the I'_3 contour extends outside the pink angular region, and the contour integral diverges. When applied to the case of the massive scalar exchange amplitude studied in Section 2.3, we have a better asymptotic

property that

$$\Theta(z) = [0, 2\pi) \quad \forall z \in \mathbb{C}. \tag{94}$$

In such case, $\text{Im} \Psi^{12 \leftrightarrow 34}(\beta, z)$ in the region $1 > z > 0$ can also be computed by the fan-like contour $I_2 + I'_2 + I'_3$, which picks up the residues and discontinuities of the poles and branch cuts inside the contour. The result is

$$\begin{aligned} \text{Im} \Psi_{>\Lambda}^{12 \leftrightarrow 34}(\beta, z) &= -B^{12 \leftrightarrow 34}(z) \pi \sum_i \text{Res}_{\omega \rightarrow m_i, \sqrt{\frac{z}{1-z}} m_i} \left[\omega^{\beta-1} T^{12 \leftrightarrow 34}(\omega, z) \right] \\ &+ \left(\int_M^\infty + \int_{\sqrt{\frac{z}{1-z}} M}^\infty \right) d\omega \omega^{\beta-1} \text{Disc} \left[T^{12 \leftrightarrow 34}(\omega, z) \right] \quad (1 > z > 0). \end{aligned} \tag{95}$$

We see that the imaginary part of (86) indeed agrees with the formula (95).

6 Celestial dispersion relation

The analyticity properties of a scattering amplitude $T(s, t)$ can be summarized by dispersion relations. When the Mandelstam variable $u = u_0$ is fixed with the absolute value $|u_0|$ smaller than the multi-particle production threshold M , the dispersion relation for the scattering amplitude reads⁸

$$\begin{aligned} T(s, t) &= - \sum_i \frac{g_i^2}{s - m_i^2} - \sum_i \frac{g_i^2}{t - m_i^2} \\ &+ \frac{1}{\pi} \int_{M^2}^\infty ds' \frac{\text{Disc}_s [T(s', t)]}{s' - s} + \frac{1}{\pi} \int_{M^2}^\infty dt' \frac{\text{Disc}_t [T(s, t')]}{t' - t}, \end{aligned} \tag{96}$$

where the discontinuity $\text{Disc}_s [T(s, t)]$ is defined by

$$\text{Disc}_s [T(s, t)] = \frac{1}{2i} (T(s + i\epsilon, t) - T(s - i\epsilon, t)), \tag{97}$$

and similarly for $\text{Disc}_t [T(s, t)]$. By unitarity, they are positively expandable on appropriate orthogonal polynomials. Along the line of S-matrix bootstrap, the dispersion relations have been used recently to constrain the EFT coefficients – the expansion coefficients of the amplitude $T(s, t)$ at $s = u = t = 0$ [23, 25–28].

On the celestial sphere, on one hand, as we have seen in Section 3, the poles and discontinuities that appear on the right hand side of the dispersion relation (96) contribute to the imaginary part of the celestial amplitude. On the other hand, as elucidated in [21] and also discussed in Section 2.2, the EFT coefficients show up as the residues of the poles in the celestial amplitude on the complex β -plane at negative even integers. Therefore, it is natural to expect a relation between the residues of the poles at $\beta = -2n$ for $n \in \mathbb{Z}_{\leq 0}$ and the imaginary part of the celestial amplitude, given by the projection of the dispersion relation (96) on the celestial sphere. However, the dispersion relation (96) cannot be directly translated to the celestial sphere by the Mellin transform (28), since for generic z , the ω -integral extends to the region where all the Mandelstam variables are large and the dispersion relation (96) does not hold. Keeping $u = u_0$ fixed and finite corresponds to the OPE limit (colinear limit) of the celestial amplitude, for example, the $z \rightarrow \infty$ limit in the $12 \leftrightarrow 34$ kinematics.

⁸We assume the asymptotic behavior of the amplitude as $T(s, -s - u_0) \rightarrow 0$ when $|s| \rightarrow \infty$. For amplitudes with worse asymptotic behavior like $T(s, -s - u_0) \rightarrow |s|^N$ when $|s| \rightarrow \infty$, similar dispersion relations can be written down with N unknown coefficients known as subtraction constants.

From the celestial amplitude of the massive scalar exchange (37), we observe the following relation between the residues of the poles at negative even integer β and the imaginary part of the celestial amplitude

$$\frac{\pi}{2} \operatorname{Res}_{\beta \rightarrow -2n} [\Psi_{\text{scalar}}^{12 \leftrightarrow 34}(\beta, z)] = \operatorname{Im} [\Psi_{\text{scalar}}^{12 \leftrightarrow 34}(\beta, z) + (-1)^n \Psi_{\text{scalar}}^{13 \leftrightarrow 24}(\beta, z)] \Big|_{\beta \rightarrow -2n} \quad (z \geq 1), \quad (98)$$

and similar relations in the other regions. Importantly, the celestial amplitude $\Psi_{\text{scalar}}^{13 \leftrightarrow 24}(-2n, z)$ on the right hand side is given by the analytic continuation from the physical defining region $1 > z > 0$ to the region $z > 1$, as discussed in Section 5.1. Note that we could have chosen the analytic continuation of $\Psi_{\text{scalar}}^{14 \leftrightarrow 23}$ instead, since from eq.(89), $\Psi_{\text{scalar}}^{13 \leftrightarrow 24}(\beta, z) = \Psi_{\text{scalar}}^{14 \leftrightarrow 23}(\beta, z)$ when $z \geq 1$.

More general celestial amplitudes satisfy a similar celestial dispersion relation,

$$\frac{\pi}{2} \operatorname{Res}_{\beta \rightarrow -2n} [\Psi^{12 \leftrightarrow 34}(\beta, z)] = \operatorname{Im} [\Psi^{12 \leftrightarrow 34}(\beta, z) + (-1)^n \Psi^{13 \leftrightarrow 24}(\beta, z)] \Big|_{\beta \rightarrow -2n} \quad (z \geq 1). \quad (99)$$

In the above, we take $n \geq 1$ if gravity is non-dynamical and $n > 1$ when graviton exchange are involved. The celestial amplitude $\Psi^{13 \leftrightarrow 24}(-2n, z)$ on the right hand side of (99) is given by the analytic continuation from the physical region $1 \geq z \geq 0$ to the region $z \geq 1$, as discussed in Section 5.

Let us now derive (99). First we note that the original Mellin integral (28) can be written as a contour integral along the negative real axes:

$$\Psi^{12 \leftrightarrow 34}(\beta, z) = \frac{1}{2i} \operatorname{csc}(\pi\beta) B^{12 \leftrightarrow 34}(z) \oint_{\mathcal{C}_{(-\infty, 0]}} d\omega \omega^{\beta-1} T^{12 \leftrightarrow 34}(\omega, z), \quad (100)$$

where the contour $\mathcal{C}_{(-\infty, 0]}$ is a thin counterclockwise contour along the negative real axes that picks up the discontinuity across the branch cut associated with the $\omega^{\beta-1}$ factor, as shown in the left of figure 6. Note that we've used $i\epsilon$ to push the cuts associated with T on to the complex ω plane. This identity can be understood by noting that

$$\operatorname{Disc}[\omega^{\beta-1}] = \frac{1}{2i} [(|\omega|e^{i\pi})^{\beta-1} - (|\omega|e^{-i\pi})^{\beta-1}] = -\sin(\pi\beta)|\omega|^{\beta-1}, \quad \text{when } \omega \in (-\infty, 0]. \quad (101)$$

via. change of variable, we recover the original Mellin integral. This formula makes the pole structure of the celestial amplitude manifest as the $\operatorname{csc}(\pi\beta)$ pre-factor, and the contour integral along $\mathcal{C}_{(-\infty, 0]}$ converges on the entire β -plane. With this formula, the celestial amplitude $\Psi(\beta, z)$ can be analytically continued to $\beta \leq 0$. The pre-factor $\operatorname{csc}(\pi\beta)$ has simple poles at $\beta \in \mathbb{Z}_{\leq 0}$, for which $\omega^{\beta-1}$ yields a (multi)pole at $\omega = 0$. Thus when computing the residue for $\beta \in \mathbb{Z}_{\leq 0}$, the contour $\mathcal{C}_{(-\infty, 0]}$ is contracted to a small circle \mathcal{C}_0 centered at the origin. We then arrive at⁹

$$\operatorname{Res}_{\beta \rightarrow -2n} [\Psi^{12 \leftrightarrow 34}(\beta, z)] = \frac{1}{2\pi i} B(z) \oint_{\mathcal{C}_0} d\omega \omega^{-2n-1} T^{12 \leftrightarrow 34}(\omega, z). \quad (102)$$

To proceed, let us impose on $T^{12 \leftrightarrow 34}(\omega, z)$ the boundedness condition introduced previously around (39) and also the following condition:

Analyticity: The amplitude $T^{12 \leftrightarrow 34}(\omega, z)$ is analytic inside the fan-shaped contour \mathcal{C}'_0 as shown in figure 6, with the extension angle determined by $\theta_c^{12 \leftrightarrow 34}$ in (39).

The poles and branch cuts located near the real or imaginary axis on the ω -plane correspond to the physical thresholds, i.e. the exchange of single or multi-particle states. At loop

⁹The residues of the poles at $\beta = -2n - 1$ all equal to zero, because $T(\omega, z)$ is an even function in ω .

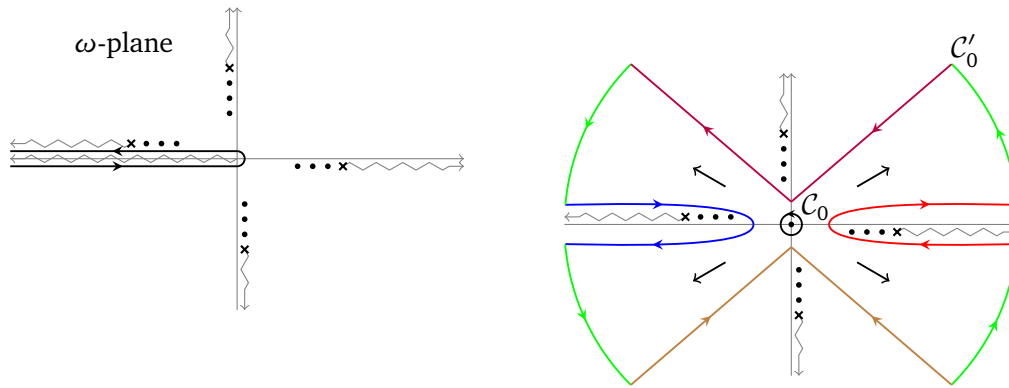

Figure 6: **Left:** The contour $C_{(-\infty, 0]}$. **Right:** Pulling the contour C_0 to C'_0 , which further decomposes into the red contour D_0 , the blue contour D_1 , the purple contour D_2 , the brown contour D_3 , and finally the green contours.

levels, there are potentially also poles or branch cuts from anomalous thresholds located away from the real or imaginary axis. The analyticity assumption is amount to forbid their appearance inside C'_0 . Now, let us pull the contour C_0 to the C'_0 . Due to the boundedness assumption, the arcs of the contour C'_0 at infinite (the green contours) do not contribute to the integral.

The remaining part of the contour C'_0 decomposes into four pieces: the red contour D_0 , the blue contour D_1 , the purple contour D_2 , and the brown contour D_3 . The contour integral along D_1 can be simply related to the contour integral along D_0 and using (43), we get

$$\begin{aligned} \frac{\pi z^2}{2\pi i} \int_{D_1} d\omega \omega^{-2n-1} T^{12 \rightarrow 34}(\omega, z) &= e^{-2n\pi i} \frac{\pi z^2}{2\pi i} \int_{D_0} d\omega \omega^{-2n-1} T^{12 \rightarrow 34}(\omega, z) \\ &= \frac{1}{\pi} \mathbf{Im}[\Psi^{12 \rightarrow 34}(\beta, z)]. \end{aligned} \tag{103}$$

Next, performing the change of variable $\omega = i\sqrt{z}\omega'$, we find:

$$\frac{\pi z^2}{2\pi i} \int_{D_2 + D_3} d\omega \omega^{-2n-1} T^{12 \rightarrow 34}(\omega, z) = \frac{(-1)^n}{2i} z^{2-n} \int_{D'_2 + D'_3} d\omega' (\omega')^{-2n-1} T^{13 \rightarrow 24}(\omega', z), \tag{104}$$

where D'_2 and D'_3 are the contours given by rotating the contours D_2 and D_3 clockwise around origin by $\pi/2$. The contour integral along D'_3 can be simply related to the contour integral along D'_2 , which equals to the $I_2 + I'_2$ in Figure 5 contour that computes the imaginary part of the analytic continued celestial amplitude. More explicitly, we have

$$\begin{aligned} \frac{z^{2-n}\pi}{2i} \int_{D'_3} d\omega' (\omega')^{-2n-1} T^{13 \rightarrow 24}(\omega, z) &= e^{-2\pi n i} \frac{z^{2-n}\pi}{2i} \int_{D'_2} d\omega' (\omega')^{-2n-1} T^{13 \rightarrow 24}(\omega, z) \\ &= \mathbf{Im}[\Psi^{13 \rightarrow 24}(\beta, z)]. \end{aligned} \tag{105}$$

Putting everything together, we find the celestial dispersion relation (99).

Note that for the amplitude of the massive scalar exchange (34), since the amplitude vanishes in all direction, we can instead deform the contour to C'_0 in Figure 7. Therefore, the integral picks up contributions from the poles and branch cuts near the real axis and gives the

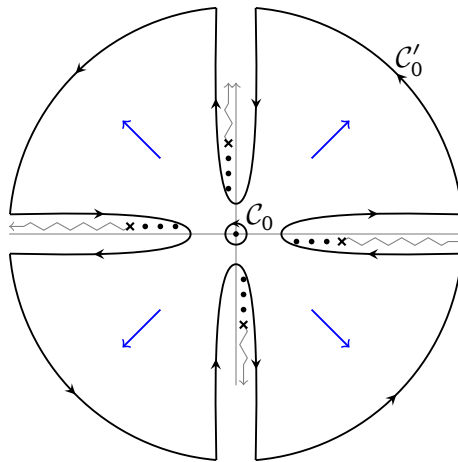

Figure 7: Contour deformation from C_0 to C'_0 .

imaginary part of $\Psi^{12\leftrightarrow 34}(\beta, z)$ by (43). The contribution from the imaginary axis is

$$-B(z) \left\{ \pi \sum_i \operatorname{Res}_{\omega \rightarrow i\sqrt{z}m_i, i\sqrt{\frac{z}{z-1}}m_i} \left[\omega^{-2n-1} T^{12\leftrightarrow 34}(\omega, z) \right] + \left(\int_{i\sqrt{z}M}^{i\infty} + \int_{i\sqrt{\frac{z}{z-1}}M}^{i\infty} \right) d\omega \omega^{-2n-1} \operatorname{Disc} \left[T^{12\leftrightarrow 34}(\omega, z) \right] \right\}, \quad (106)$$

which equals to $\operatorname{Im} [(-1)^n \Psi^{13\leftrightarrow 24}(-2n, z)]$ or $\operatorname{Im} [(-1)^n \Psi^{14\leftrightarrow 23}(-2n, z)]$, by the formulae similar to (95) with the appropriate changes of the integration variable, $\omega \rightarrow i\sqrt{z}\omega$ or $\omega \rightarrow i\sqrt{\frac{z}{z-1}}\omega$.

6.1 Celestial dispersion relation in string theory

Let us do the numerical check of our conjecture (99) for the celestial dispersion relation, by considering the open and closed string celestial amplitudes. Specifically, we will give the analytic form of the residues at $\beta = -10$ and $\beta = -12$ poles and numerically evaluate $\operatorname{Im} \Psi^{12\leftrightarrow 34}$ and $\operatorname{Im} \Psi^{13\leftrightarrow 24}$ through the fan-like integrals as indicated in (103) and (105). Finally, we will plot the results above and show they indeed match.

- Numeric results of $\beta = -10$
The analytic forms of residues at the $\beta = -10$ poles of open and closed string celestial amplitude are,

$$\begin{aligned} & \frac{\pi}{2} \operatorname{Res}_{\beta \rightarrow -10} \left[\Psi_{\text{open}}^{12\leftrightarrow 34}(\beta, z) \right] \\ &= \frac{512\pi}{45z^3} \left[-\pi^4 z(-1+z)(4+7z(-1+z))\zeta(3) - 60\pi^2 z(-1+z)(1+z(-1+z))\zeta(5) \right. \\ & \quad \left. - 360(1+z(-1+z))^2\zeta(7) \right], \\ & \frac{\pi}{2} \operatorname{Res}_{\beta \rightarrow -10} \left[\Psi_{\text{closed}}^{12\leftrightarrow 34}(\beta, z) \right] = -\frac{16384\pi(-1+z)[1+z(-1+z)]\zeta(3)\zeta(5)}{z^2}, \end{aligned} \quad (107)$$

where $\zeta(x)$ is the Riemann zeta function. The comparison with the RHS of (99) is shown in Figure 8.

- Numeric results of $\beta = -12$
The analytic forms of residues at the $\beta = -12$ poles of open and closed string celestial

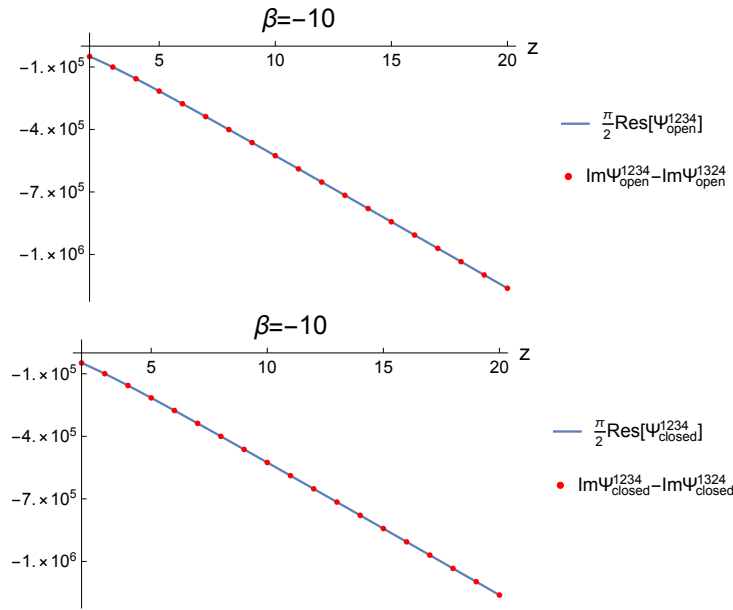

Figure 8: The comparison between the analytic formula for the residue at $\beta = -10$ and the numerical evaluation of the imaginary part for the open and closed string celestial amplitudes.

amplitude are,

$$\begin{aligned}
 & \frac{\pi}{2} \text{Res}_{\beta \rightarrow -12} \left[\Psi_{\text{open}}^{12 \leftrightarrow 34}(\beta, z) \right] \\
 &= \frac{128\pi}{14175z^4} \left[\pi^8 (-192 - z(-1 + z))(912 + z(-1 + z)(1256 + 381z(-1 + z))) \right. \\
 &\quad - 151200\pi^2 \zeta(3)^2 (-1 + z)^2 z^2 \\
 &\quad \left. - 1814400\zeta(3)\zeta(5)z(-1 + z)(1 + z(-1 + z)) \right], \tag{108} \\
 & \frac{\pi}{2} \text{Res}_{\beta \rightarrow -12} \left[\Psi_{\text{closed}}^{12 \leftrightarrow 34}(\beta, z) \right] \\
 &= \frac{256\pi}{945z^4} \left[3\psi^{(8)}(1) + 9z(-1 + z) \right. \\
 &\quad \left. \times \left(\psi^{(8)}(1) - 4480z(-1 + z)(2\zeta(3)^3 + (10 + 3z(-1 + z)\zeta(9))) \right) \right],
 \end{aligned}$$

where $\psi^{(n)}(z)$ is the polygamma function. The comparison is given in Figure 9.

6.2 OPE limit

In the celestial dispersion relation, on the right hand side, the first term $\text{Im} \Psi^{12 \leftrightarrow 34}(\beta, z)$ equals to a sum over the contributions from the s -channel exchange as discussed in Section 3. However, in general, the second term $\text{Im} \Psi^{13 \leftrightarrow 24}(\beta, z)$ cannot be expressed as a sum over contributions from exchange process. The obstruction is due to the fact that in general the amplitude $T^{13 \leftrightarrow 24}(\omega, z)$ does not converge in the $\omega \rightarrow \infty$ limit when $z > 1$, and thereby we cannot closed the $I_2 + I'_2$ contour in Figure 5.¹⁰ This is exactly the case for the open and closed string amplitudes, as we have seen in the above analysis that $\text{Im} \Psi_{\text{open/closed}}^{13 \rightarrow 24}(\beta, z)$ cannot be expressed as a sum over residues.

¹⁰The analysis around Figure 5 is for analytic continuing $T^{12 \leftrightarrow 34}(\omega, z)$ from $z > 1$ to $1 > z > 0$, but we can repeat the same analysis for analytic continuing $T^{13 \leftrightarrow 24}(\omega, z)$ from $1 > z > 0$ to $z > 1$, and the Figure 5 still applies upon reinterpreted the black, blue and red dots as representatives for the u -, s -, and t -channel poles.

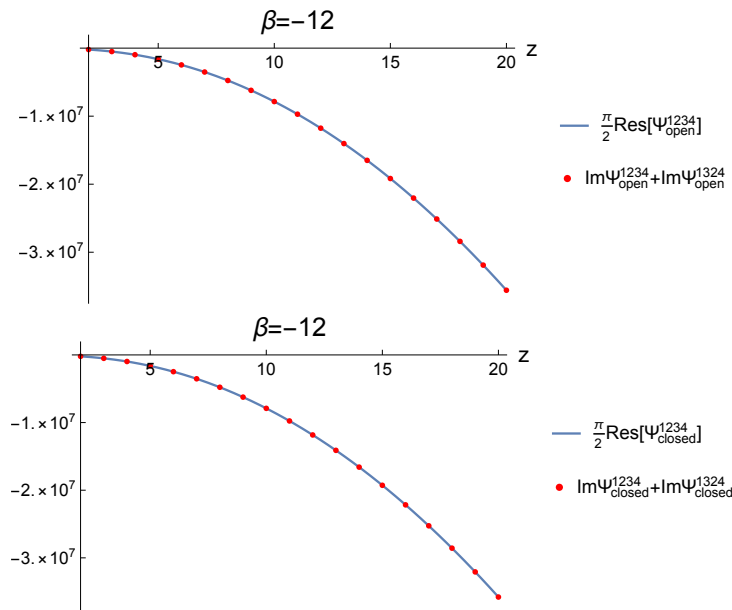

Figure 9: The comparison between the analytic formula for the residue at $\beta = -10$ and the numerical evaluation of the imaginary part for the open and closed string celestial amplitudes.

However, the high energy behaviors of the string scattering amplitudes become nicer in the OPE limit (co-linear limit). This would allow us to close the $I_2 + I'_2$ contour for the leading terms in the OPE. In the following analysis, we choose to work with $\text{Im} \Psi_{\text{open/closed}}^{14 \rightarrow 23}(\beta, z)$ by noting the relations (89). Let us expand the open string amplitude (70) in the OPE limit $z \rightarrow \infty$ as

$$T_{\text{open}}^{14 \leftrightarrow 23}(\omega, z) = T_{\text{open}} \left(\frac{z}{1-z} \omega^2, \omega^2 \right) = \sum_{m=0}^{\infty} T_{\text{open}}^{14 \leftrightarrow 23, (m)}(\omega) z^{-m}. \quad (109)$$

From the explicit amplitude (70), we find that in the high energy limit $\omega \rightarrow \infty$ the expansion coefficients behave as

$$T_{\text{open}}^{14 \leftrightarrow 23, (m)}(\omega) \sim \omega^{2m-2} \csc(\pi \omega^2) \log^m(\omega). \quad (110)$$

The $I_2 + I'_2$ contour in Figure 5 can be closed at infinity when $\beta \leq -2m + 2$. Hence, the leading terms in the expansion of $\text{Im} \Psi_{\text{open}}^{14 \rightarrow 23}(\beta, z)$ can be computed by a sum over the residue of the t -channel poles. For example, we have

$$\begin{aligned} \text{Im} \left[\Psi_{\text{open}}^{14 \rightarrow 23}(\beta, z) \right] \Big|_{\beta \rightarrow 0} &= -\pi B^{14 \rightarrow 23}(z) \left[\sum_{n=1}^{\infty} \frac{(-1)^{n+1}}{2n^2} + \sum_{n=1}^{\infty} \frac{(-1)^{n+1} (\psi^{(0)}(n) + \gamma)}{2n} z^{-1} + \mathcal{O}(z^{-2}) \right] \\ &= -\pi B^{14 \rightarrow 23}(z) \left[\frac{\pi^2}{24} - \frac{1}{4} \log^2(2) z^{-1} + \mathcal{O}(z^{-2}) \right]. \end{aligned} \quad (111)$$

Similarly, the closed string amplitude (73) expanded in the OPE limit $z \rightarrow \infty$ gives

$$T_{\text{closed}}^{14 \leftrightarrow 23}(\omega, z) = T_{\text{closed}} \left(\frac{z}{1-z} \omega^2, \omega^2 \right) = \sum_{m=-1}^{\infty} T_{\text{closed}}^{14 \leftrightarrow 23, (m)}(\omega) z^{-m}. \quad (112)$$

In the high energy limit $\omega \rightarrow \infty$, we find that the expansion coefficients behave as

$$T_{\text{closed}}^{14 \leftrightarrow 23, (m)}(\omega) \sim \omega^{2m-4} \log^{m+1}(\omega). \quad (113)$$

The $I_2 + I'_2$ contour can be closed when $\beta < -2m + 4$. Again, the leading terms in the expansion of $\text{Im}\Psi_{\text{closed}}^{14 \rightarrow 23}(\beta, z)$ can be computed by a sum over the residue of the t -channel poles. For example, we have

$$\begin{aligned} \text{Im}\left[\Psi_{\text{open}}^{14 \rightarrow 23}(\beta, z)\right] \Big|_{\beta \rightarrow 0} &= -\pi B^{14 \rightarrow 23}(z) \left[\sum_{n=1}^{\infty} \frac{1}{2n^3} + \sum_{n=1}^{\infty} \frac{\psi^{(0)}(n) + \gamma}{n^2} z^{-1} + \mathcal{O}(z^{-2}) \right] \\ &= -\pi B^{14 \rightarrow 23}(z) \left[\frac{\zeta(3)}{2} + \zeta(3)z^{-1} + \mathcal{O}(z^{-2}) \right]. \end{aligned} \tag{114}$$

One can similarly compute the imaginary part of the open and closed string celestial amplitudes in the OPE limit for other non-positive integer β and verify the celestial dispersion relation for the leading orders in the large z expansion.

7 Conclusion and outlook

In this paper, we studied the relations between the bulk-locality, unitarity and analyticity of the celestial amplitudes.

1. We showed that the imaginary part of the celestial amplitude can be expressed as the integral along the fan-like contour (the right plot in Figure 1) that encloses the positive real axis on the complex plane of the center of mass energy ω . The exchanges of single- and multi-particle states produce poles and branch cuts near the positive real axis and contribute to the fan-like contour integral. This demonstrates that the imaginary part of the celestial amplitude is given by bulk factorization singularities.
2. By unitarity, the imaginary part of the celestial amplitude can be positively expanded in the basis of Legendre or Jacobi polynomials for scalar or spinning particle amplitudes. The projection of these orthogonal polynomials onto the celestial sphere can be matched to the Poincaré partial waves that satisfy the massive Casimir equation of the Poincaré algebra.
3. The four-point celestial amplitude from three distinct physical kinematic configurations tiles the equator of the celestial sphere. On the boundary of each region that functions on the two sides are not continuously connected. Instead we studied the analytic continuation of the celestial amplitude from the physical regions (the intervals listed in Table 1) to the to the unphysical region.
4. Assuming specific high energy behaviour for the flat-space amplitude for complex scattering angles, we prove a celestial version of the dispersion relation (99). This allows us to relate the residues of the poles of the celestial amplitude at negative even integers on the complex β -plane, which yields the EFT coefficients, to the imaginary part of the celestial amplitude and its analytic continuation.
5. These results are verified in the context of the open and closed string amplitudes.

In defining the fan contour, we've assumed that the amplitude is well behaved as $\omega \rightarrow \infty$ even as ω is continued on to the complex plane with a small angle. While we've shown that this holds for scalar exchange and string theory amplitudes, it will be desirable to derive such behaviour from some general principle.

The celestial dispersion relation is reminiscent of the Zamolodchikov's recursive representation for the conformal blocks [29–31]. When tuning the conformal dimension of a primary

operator to some special values, certain descendant operators become zero norm and decouple from the conformal multiplet. This phenomenon reflects on the conformal block as poles on the complex conformal dimension plane whose residues are the conformal blocks formed by the zero norm descendants. In our celestial dispersion relation (99), we see that the residue of the poles at negative even integer β are the imaginary part of the celestial amplitude, which can be further expanded in terms of the Poincaré partial waves. It would be interesting to see if the origin of these poles can be traced by to the exchange of some zero norm states in the celestial CFT.

Acknowledgments

We would like to thank Shu-Heng Shao and Yu-Chi Hou for enlightening discussions. Cm C would like to thank the hospitality of NTU high-energy theory group. Cm C is partly supported by National Key R&D Program of China (NO. 2020YFA0713000). Yt H, and Zx H is supported by MoST Grant No. 109-2112-M-002 -020 -MY33. Yt H is also supported by Golden Jade fellowship.

A Four-point helicity amplitude

Let us consider a four-point amplitude of massless particles with helicities ℓ_i for $i = 1, \dots, 4$. The amplitude can be expressed as a function of the angle brackets $\langle ij \rangle$ and the square brackets $[ij]$. The Mandelstam variables are products of angle and square brackets, $s_{ij} = \langle ij \rangle [ji]$. Hence, we can instead choose to express the amplitude as a function of the angle bracket $\langle ij \rangle$ and s, t . There are relations among these variables. First, we have the Schouten identity

$$\langle 41 \rangle \langle 23 \rangle + \langle 42 \rangle \langle 31 \rangle + \langle 43 \rangle \langle 12 \rangle = 0. \quad (115)$$

We also have relations from the momentum conservation

$$\frac{\langle 23 \rangle}{\langle 13 \rangle}(-s-t) + \frac{\langle 24 \rangle}{\langle 14 \rangle}t = 0, \quad \frac{\langle 12 \rangle}{\langle 32 \rangle}t + \frac{\langle 14 \rangle}{\langle 34 \rangle}s = 0, \quad \frac{\langle 12 \rangle}{\langle 42 \rangle}(-s-t) + \frac{\langle 13 \rangle}{\langle 43 \rangle}s = 0. \quad (116)$$

We can rewrite the left hand side of the above equation as a 3×2 matrix acting on the vector (s, t) , and the Schouten identity implies that all the second minors of matrix vanish. Hence, the relations (116) all linearly relate to each others.

Using (115) and (116), we can write the amplitude as a function of the variables

$$\langle 12 \rangle, \quad \langle 13 \rangle, \quad \langle 14 \rangle, \quad \langle 34 \rangle, \quad s, \quad t, \quad (117)$$

or equivalently as a function of the variables

$$\begin{aligned} \frac{z_{12}}{\bar{z}_{12}} &= -\epsilon_1 \epsilon_2 \frac{\langle 12 \rangle^2}{s}, & \frac{z_{13}}{\bar{z}_{13}} &= \epsilon_1 \epsilon_3 \frac{\langle 13 \rangle^2}{s+t}, & \frac{z_{14}}{\bar{z}_{14}} &= -\epsilon_1 \epsilon_4 \frac{\langle 14 \rangle^2}{t}, \\ \frac{z_{34}}{\bar{z}_{34}} &= -\epsilon_3 \epsilon_4 \frac{\langle 34 \rangle^2}{s}, & s, & t. \end{aligned} \quad (118)$$

Now, using the constraint from the $SL(2, \mathbb{C})$ symmetry (12), we find

$$\begin{aligned} \mathcal{A}_{\ell_i}(\omega_i, z_i) &= \left(\frac{z_{12}}{\bar{z}_{12}}\right)^{-\ell_2} \left(\frac{z_{13}}{\bar{z}_{13}}\right)^{\frac{-\ell_1+\ell_2-\ell_3+\ell_4}{2}} \left(\frac{z_{14}}{\bar{z}_{14}}\right)^{\frac{-\ell_1+\ell_2+\ell_3-\ell_4}{2}} \left(\frac{z_{34}}{\bar{z}_{34}}\right)^{\frac{\ell_1-\ell_2-\ell_3-\ell_4}{2}} \\ &\quad \times \delta^{(4)}(p_1 + p_2 + p_3 + p_4) T(s, t) \\ &= \delta^{(4)}(p_1 + p_2 + p_3 + p_4) \frac{\left(\frac{z_{14}\bar{z}_{13}}{\bar{z}_{14}\bar{z}_{13}}\right)^{\frac{\ell_3-\ell_4}{2}} \left(\frac{z_{24}\bar{z}_{14}}{\bar{z}_{24}\bar{z}_{14}}\right)^{\frac{\ell_1-\ell_2}{2}}}{\left(\frac{z_{12}}{\bar{z}_{12}}\right)^{\frac{\ell_1+\ell_2}{2}} \left(\frac{z_{34}}{\bar{z}_{34}}\right)^{\frac{\ell_3+\ell_4}{2}}} T(s, t), \end{aligned} \tag{119}$$

where in the second equality we have used the identities (116).

B Poincaré generators on single particle states

The Poincaré generators P^μ and $M^{\mu\nu}$ acting on a massless single particle state $|\Delta, z, \ell\rangle$ in the conformal primary basis as

$$P^\mu |\Delta, z, \ell\rangle = \mathcal{P}^\mu |\Delta, z, \ell\rangle, \quad M^{\mu\nu} |\Delta, z, \ell\rangle = \mathcal{M}^{\mu\nu} |\Delta, z, \ell\rangle, \tag{120}$$

where \mathcal{P}^μ and $\mathcal{M}^{\mu\nu}$ are differential operators, whose explicit form are given by [12]

$$\begin{aligned} \mathcal{M}^{01} &= \frac{i}{2} [(\bar{z}^2 - 1)\bar{\partial} + (z^2 - 1)\partial + 2(\bar{h}\bar{z} + hz)], \\ \mathcal{M}^{02} &= -\frac{1}{2} [(\bar{z}^2 + 1)\bar{\partial} - (z^2 + 1)\partial + 2(\bar{h}\bar{z} - hz)], \\ \mathcal{M}^{03} &= i(\bar{z}\bar{\partial} + z\partial + \bar{h} + h), \\ \mathcal{M}^{12} &= -\bar{z}\bar{\partial} + z\partial - \bar{h} + h, \\ \mathcal{M}^{13} &= \frac{i}{2} [(\bar{z}^2 + 1)\bar{\partial} + (z^2 + 1)\partial + 2(\bar{h}\bar{z} + hz)], \\ \mathcal{M}^{23} &= -\frac{1}{2} [(\bar{z}^2 - 1)\bar{\partial} - (z^2 - 1)\partial + 2(\bar{h}\bar{z} - hz)], \end{aligned} \tag{121}$$

and

$$\mathcal{P}^\mu = 2q^\mu e^{\partial_\Delta}. \tag{122}$$

C Analytic continuation of the string amplitudes

In this appendix, we apply the analytic continuation procedure in Section 5.2 to the open and closed string amplitudes. As discussed in Section 5.2, the integration contour of the celestial amplitude are being continuously deformed when going along the path (90). The integration contour should asymptote to the angle inside the convergent region $\Theta^{12\leftrightarrow 34}(z)$. Hence, we need to ensure that the convergent region varies continuously along the path (90). Let us parametrize the string amplitudes (70) and (73) as

$$s = \omega^2, \quad t = -\frac{z-1}{z}\omega^2, \quad \omega = re^{i\theta}, \quad z = 1 + \epsilon e^{-i\phi}. \tag{123}$$

The amplitudes vanish in the limit $r \rightarrow \infty$ when the angles θ and ϕ are inside the region plotted in Figure 10. We see that we can indeed find continuous deformations of the integration contours which are always inside the convergent regions.

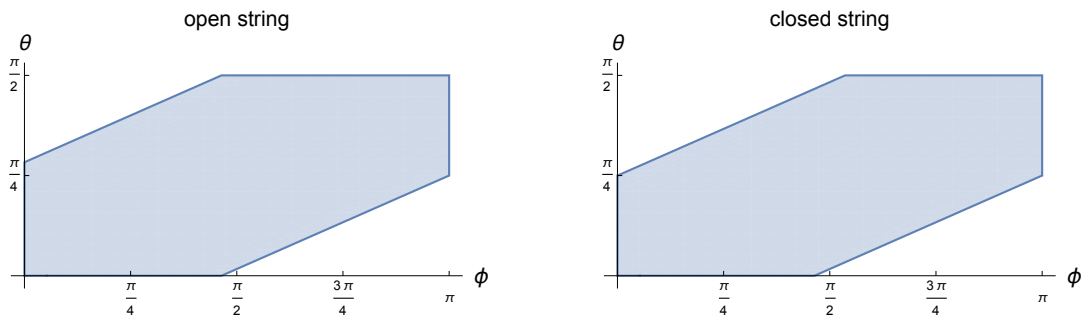

Figure 10: The convergence region $\Theta^{12\leftrightarrow 34}(z)$ of the open and closed string amplitudes for $\epsilon = 10^{-6}$.

D Conformal partial wave representation

The four-point celestial amplitude (16) can be expanded in the conformal partial wave basis as

$$f_{\Delta_i, \ell_i}(z, \bar{z}) = \sum_{\ell=-\infty}^{\infty} \int_0^{\infty} \frac{d\nu}{2\pi} \frac{p_{\ell}(\Delta_i, \ell_i; \nu)}{n_{\ell}(\nu)} \Psi_{\Delta_i, \ell_i; 1+i\nu, \ell}^{\text{conf.}}(z, \bar{z}), \quad (124)$$

where $\Psi_{\Delta_i, \ell_i; 1+i\nu, \ell}^{\text{conf.}}(z, \bar{z})$ is the conformal partial wave normalized such that

$$\frac{1}{2} \int \frac{d^2z}{|z|^4} \Psi_{\Delta_i, \ell_i; 1+i\nu, \ell}^{\text{conf.}}(z, \bar{z}) \Psi_{1-\Delta_i, -\ell_i; 1-i\nu', -\ell'}^{\text{conf.}}(z, \bar{z}) = n_{\ell}(\nu) \times 2\pi \delta_{\ell, \ell'} \delta(\nu - \nu'), \quad (125)$$

for external dimensions in the principal series, i.e. $\Delta_i \in 1 + i\mathbb{R}$. The normalization $n_{\ell}(\nu)$ is¹¹

$$n_{\ell}(\nu) = \frac{2\pi^3}{\ell^2 + \nu^2}. \quad (126)$$

For the scalar amplitude with the tree-level massive scalar exchange in the $12 \leftrightarrow 34$ kinematics, the imaginary part of the expansion coefficient $p_{\ell}(\Delta_i; \nu)$ factorizes as [6]

$$\text{Im } p_{\ell}(\Delta_i; \nu) = \delta_{\ell, 0} \pi^2 m^2 C_{\Delta_1, \Delta_2; 1+i\nu} C_{\Delta_3, \Delta_4; 1-i\nu}, \quad (127)$$

where $C_{\Delta_1, \Delta_2; \Delta_3}$ is the 3-point coefficient of the celestial amplitude of two massless and one massive scalars. Using the shadow representation of the conformal partial wave, the factorization (127) is equivalent to

$$\begin{aligned} \text{Im } \tilde{\mathcal{A}}_{\Delta_i}^{12\leftrightarrow 34}(z_i, \bar{z}_i) &= \int_0^{\infty} \frac{d\nu}{2\pi} \frac{\pi^2 m^2}{n_{\ell}(\nu)} \int d^2z \\ &\times \tilde{\mathcal{A}}_{3, \Delta_1, \Delta_2; 1+i\nu}(z_1, \bar{z}_1, z_2, \bar{z}_2, z, \bar{z}) \tilde{\mathcal{A}}_{3, \Delta_3, \Delta_4; 1-i\nu}(z_3, \bar{z}_3, z_4, \bar{z}_4, z, \bar{z}), \end{aligned} \quad (128)$$

where $\tilde{\mathcal{A}}_{\Delta_1, \Delta_2; \Delta_3}(z_i, \bar{z}_i)$ is the three-point celestial amplitude,

$$\tilde{\mathcal{A}}_{\Delta_1, \Delta_2; \Delta_3}(z_i, \bar{z}_i) = \frac{C_{\Delta_1, \Delta_2; \Delta_3}}{|z_{12}|^{\Delta_1 + \Delta_2 - \Delta_3} |z_{13}|^{\Delta_1 + \Delta_3 - \Delta_2} |z_{23}|^{\Delta_2 + \Delta_3 - \Delta_1}}. \quad (129)$$

In this appendix, we generalize the above result to the four-point scalar celestial amplitude with the tree-level massive spin- J particle exchange. We show that the imaginary part of such

¹¹We follow the convention in [32, 33].

an amplitude factorizes as an integral of a product of two three-point celestial amplitudes of two massless scalars and one massive spin- J particle,

$$\begin{aligned} \text{Im } \tilde{\mathcal{A}}_{\Delta_i, J}^{12 \leftrightarrow 34}(z_i, \bar{z}_i) &= \pi^2 m^{2J+2} J! \sum_{\ell=-J}^J \int_0^\infty \frac{d\nu}{2\pi} \frac{\mu_{J, \ell}(\nu)}{2^{|\ell|} n_\ell(\nu)} \int d^2z \\ &\times \tilde{\mathcal{A}}_{3, \Delta_1, \Delta_2; 1+i\nu, \ell}^{(J)}(z_1, \bar{z}_1, z_2, \bar{z}_2, z, \bar{z}) \tilde{\mathcal{A}}_{3, \Delta_3, \Delta_4; 1-i\nu, -\ell}^{(J)}(z_3, \bar{z}_3, z_4, \bar{z}_4, z, \bar{z}), \end{aligned} \tag{130}$$

where $\mu_{J, \ell}(\nu)$ is

$$\mu_{J, \ell}(\nu) = (-1)^{|\ell|} \frac{2^{J-|\ell|} (|\ell| + 1)_{J-|\ell|} (|\ell| + \frac{1}{2})_{J-|\ell|}}{(J - |\ell|)! (2|\ell| + 1)_{J-|\ell|}}. \tag{131}$$

Let us first focus on the right hand side of (130). The 3-point celestial amplitude is given by the integral [34]

$$\begin{aligned} \tilde{\mathcal{A}}_{3, \Delta_i, \Delta, \ell}^{(J)}(z_i, \bar{z}_i) &= \left(\prod_{i=1}^2 \int_0^\infty d\omega_i \omega_i^{\Delta_i-1} \right) \int \frac{dy}{y^3} dz' d\bar{z}' \\ &\times \sum_{b=-J}^J G_{\ell, b}^{(J)}(\hat{k}; z, \bar{z}) A_{3, b}(p_1, p_2, k) \delta^4(k + p_1 + p_2), \end{aligned} \tag{132}$$

where $A_{3, b}(p_1, p_2, k)$ is the three-point amplitude explicitly given by

$$A_{3, b}(p_1, p_2, k) = p_{12}^{\mu_1} \dots p_{12}^{\mu_J} \epsilon_{b, \mu_1 \mu_2 \dots \mu_J}, \tag{133}$$

with all momenta outgoing. $\epsilon_{b, \mu_1 \mu_2 \dots \mu_J}$ is the polarization tensor for spin- s particle. The massless momenta p_1, p_2 are parametrized as before by $p_i = -\omega_i q_i$ and (5). The massive momentum k is parametrized by

$$k = m\hat{k}, \quad \hat{k}^\mu = \frac{1}{2y} (1 + y^2 + |z'|^2, 2\text{Re}(z'), 2\text{Im}(z'), 1 - y^2 - |z'|^2). \tag{134}$$

$G_{\ell, b}^{(J)}(\hat{k}; z, \bar{z})$ is the integration weight matrix that relates the spin- J massive irreducible representations of the little group on $\mathbb{R}^{1,3}$ to the spin- ℓ representations of the conformal group on the celestial sphere. The integration weight matrix $G_{\ell, b}^{(J)}(\hat{k}; z, \bar{z})$ is computed in [34]

$$\begin{aligned} \sum_{b=-J}^J G_{\ell, b}^{(J)}(\hat{k}; z, \bar{z}) \epsilon_b^{\mu_1 \mu_2 \dots \mu_J} &= \frac{1}{J! \left(\frac{1}{2}\right)_J} K^{\mu_1} K^{\mu_2} \dots K^{\mu_J} G_{\ell, \Delta}^{(J)}(\hat{k}, Y; z, \bar{z}) \Big|_{Y=0}, \\ G_{\ell, \Delta}^{(J)}(\hat{k}, Y; z, \bar{z}) &= \begin{cases} \frac{(Y \cdot q)^{J-\ell} [(\hat{k} \cdot q)(Y \cdot \partial_{\bar{z}} q) - (\hat{k} \cdot \partial_{\bar{z}} q)(Y \cdot q)]^\ell}{(-\hat{k} \cdot q)^{\Delta+J}} & \text{for } \ell \geq 0, \\ \frac{(Y \cdot q)^{J+\ell} [(\hat{k} \cdot \partial_z q)(Y \cdot q) - (\hat{k} \cdot q)(Y \cdot \partial_z q)]^{-\ell}}{(-\hat{k} \cdot q)^{\Delta+J}} & \text{for } \ell < 0, \end{cases} \tag{135} \\ K_\mu(\hat{k}, Y) &= \frac{1}{2} [\partial_{Y\mu} + \hat{k}_\mu (\hat{k} \cdot \partial_Y)] + (Y \cdot \partial_Y) \partial_{Y\mu} \\ &\quad + \hat{k}_\mu (Y \cdot \partial_Y) (\hat{k} \cdot \partial_Y) - \frac{1}{2} Y_\mu (\partial_Y^2 + (\hat{k} \cdot \partial_Y)^2), \end{aligned}$$

where the null vector q is parametrized by z and \bar{z} as in (5). Plugging this formula into (133), we find

$$\begin{aligned} \tilde{\mathcal{A}}_{3, \Delta_i, \Delta, \ell}^{(J)}(z_i, \bar{z}_i) &= \frac{1}{J! \left(\frac{1}{2}\right)_J} \left(\prod_{i=1}^2 \int_0^\infty d\omega_i \omega_i^{\Delta_i-1} \right) \int \frac{dy}{y^3} dz' d\bar{z}' \\ &\times \delta^4(p + p_1 + p_2) (p_{12} \cdot K)^J G_{\ell, \Delta}^{(J)}(\hat{k}, Y; z, \bar{z}). \end{aligned} \tag{136}$$

Now, the right hand side of (130) can be simplified as

$$\begin{aligned}
 & \frac{\pi^2 m^{2J+2} J!}{(J!(\frac{1}{2})_J)^2} \left(\prod_{i=1}^4 \int_0^\infty d\omega_i \omega_i^{\Delta_i-1} \right) \sum_{\ell=-J}^J \int_0^\infty \frac{d\nu}{2\pi} \frac{\mu_{J,\ell}(\nu)}{2^{|\ell|} n_\ell(\nu)} \left(\prod_{i=1}^2 \int \frac{dy_i}{y_i^3} d^2 z'_i \right) \int d^2 z \\
 & \times \delta^{(4)}(p_1 + p_2 + k_1) \delta^{(4)}(p_3 + p_4 - k_2) \\
 & \times \left[(p_{12} \cdot K(\hat{k}_1, Y_1))^J G_{\ell,1+i\nu}^{(J)}(\hat{k}_1, Y_1; z, \bar{z}) \right] \left[(p_{34} \cdot K(\hat{k}_2, Y_2))^J G_{-\ell,1-i\nu}^{(J)}(\hat{k}_2, Y_2; z, \bar{z}) \right] \Big|_{Y_1=Y_2=0} \\
 & = \frac{\pi^2 m^{2J+2} J!}{4\pi (J!(\frac{1}{2})_J)^2} \left(\prod_{i=1}^4 \int_0^\infty d\omega_i \omega_i^{\Delta_i-1} \right) \int \frac{dy_1}{y_1^3} d^2 z'_1 \delta^{(4)}(p_1 + p_2 + k_1) \delta^{(4)}(p_3 + p_4 - k_1) \\
 & \times (p_{12} \cdot K(\hat{k}_1, Y_1))^J (p_{34} \cdot K(\hat{k}_1, Y_2))^J (Y_1 \cdot Y_2)^J \Big|_{Y_1=Y_2=0} \\
 & = \pi m^{2J} \left(\prod_{i=1}^4 \int_0^\infty d\omega_i \omega_i^{\Delta_i-1} \right) \delta^{(4)}(p_1 + p_2 + p_3 + p_4) \delta(s - m^2) P_J\left(\frac{u-t}{m^2}\right),
 \end{aligned} \tag{137}$$

where in the second equality, we have used the orthogonality condition [34]

$$\sum_{\ell=-J}^J \int_{-\infty}^\infty d\nu \frac{\mu_{J,\ell}(\nu)}{2^{|\ell|} n_\ell(\nu)} \int d^2 z G_{\ell,1+i\nu}^{(J)}(\hat{k}_1, Y_1; z, \bar{z}) G_{-\ell,1-i\nu}^{(J)}(\hat{k}_2, Y_2; z, \bar{z}) = \delta(\hat{k}_1, \hat{k}_2) (Y_1 \cdot Y_2)^s, \tag{138}$$

where the delta function $\delta(\hat{k}_1, \hat{k}_2)$ is defined by

$$\int_0^\infty \frac{dy_2}{y_2^3} \int d^2 z'_2 \delta(\hat{k}_1, \hat{k}_2) F(\hat{k}_2) = F(\hat{k}_1). \tag{139}$$

In the third equality of (137), we have used the identities

$$\begin{aligned}
 & \int \frac{dy_1}{y_1^3} d^2 z'_1 \delta^{(4)}(p_1 + p_2 + k_1) = \frac{4}{m^2} \delta(s - m^2), \\
 & (p_{12} \cdot K(\hat{k}_1, Y_1))^J (p_{34} \cdot K(\hat{k}_1, Y_2))^J (Y_1 \cdot Y_2)^J \Big|_{Y_1=Y_2=0} = J! \left(\frac{(2J-1)!!}{2^J} \right)^2 P_J\left(\frac{u-t}{m^2}\right).
 \end{aligned} \tag{140}$$

Next, let us look at the left hand side of (130). The four-point celestial amplitude can be computed using the Mellin integral (6) and the formula (19) with $\ell_i = 0$,

$$\begin{aligned}
 \text{Im} \tilde{\mathcal{A}}_{\Delta_i, J}^{12 \leftrightarrow 34}(z_i, \bar{z}_i) & = \left(\prod_{i=1}^4 \int_0^\infty d\omega_i \omega_i^{\Delta_i-1} \right) \delta^{(4)}(p_1 + \dots + p_4) \\
 & \times m^{2J} \text{Im} \left[\frac{P_J\left(\frac{u-t}{m^2}\right)}{s - m^2 + i\epsilon} - \frac{P_J\left(\frac{s-t}{m^2}\right)}{u - m^2 + i\epsilon} - \frac{P_J\left(\frac{u-s}{m^2}\right)}{t - m^2 + i\epsilon} \right] \\
 & = \pi m^{2J} \left(\prod_{i=1}^4 \int_0^\infty d\omega_i \omega_i^{\Delta_i-1} \right) P_J\left(\frac{u-t}{m^2}\right) \delta(s - m^2) \delta^{(4)}(p_1 + \dots + p_4).
 \end{aligned} \tag{141}$$

(137) and (141) matches exactly; hence, the factorization formula (130) follows.

By the conformal symmetry, the three-point celestial amplitude $\tilde{\mathcal{A}}_{3, \Delta_1, \Delta_2; \Delta, \ell}^{(J)}(z_i, \bar{z}_i)$ takes the form as

$$\tilde{\mathcal{A}}_{3, \Delta_1, \Delta_2; \Delta, \ell}^{(J)}(z_i, \bar{z}_i) = \frac{C_{\Delta_1, \Delta_2; \Delta, \ell}^{(J)}}{|z_{12}|^{\Delta_1 + \Delta_2 - (\Delta - \ell)} |z_{13}|^{\Delta_1 + (\Delta - \ell) - \Delta_2} |z_{23}|^{\Delta_2 + (\Delta - \ell) - \Delta_1}} \left(\frac{z_{12}}{z_{13} z_{23}} \right)^\ell. \tag{142}$$

Plugging this into (130) and using the form (16) of the four-point celestial amplitude, we find

$$\begin{aligned} & \text{Im} f_{\Delta_i, J}^{12 \leftrightarrow 34}(z, \bar{z}) \\ &= \pi^2 m^{2J+2} J! \sum_{\ell=-J}^J \int_0^\infty \frac{d\nu}{2\pi} \frac{\mu_{J, \ell}(\nu)}{2^{\ell} |n_\ell(\nu)|} C_{\Delta_1, \Delta_2; 1+i\nu, \ell}^J C_{\Delta_3, \Delta_4; 1-i\nu, -\ell}^{-J} \Psi_{\Delta_i, \ell; 1+i\nu, \ell}^{\text{conf.}}(z, \bar{z}). \end{aligned} \quad (143)$$

Note that with the prefactor (18), the left hand side of (143) is exactly the scalar Poincaré partial wave (62), i.e.

$$\text{Im} f_{\Delta_i, \ell}^{12 \leftrightarrow 34}(z, \bar{z}) = (z-1)^{\frac{\Delta_1 - \Delta_2 - \Delta_3 + \Delta_4}{2}} \delta(iz - i\bar{z}) \Psi_{m, \ell}^{12 \leftrightarrow 34}(\Delta, z). \quad (144)$$

Thus, (143) gives a conformal partial wave representation of the scalar Poincaré partial wave!

Finally, in [34], the three-point coefficients $C_{\Delta_1, \Delta_2; \Delta_3}^J$ for $J = 0, 1, 2$ are computed, and recursion relations for the general three-point coefficients are derived. In Appendix E, we compute the general three-point coefficients by directly evaluating the Mellin integral (136).

E Computation of $C_{\Delta_1, \Delta_2; \Delta, \ell}^{(J)}$

Let us compute the structure constant $C_{\Delta_1, \Delta_2; \Delta, \ell}^{(J)}$ by explicitly working out the Mellin integral (136). The momentum conservation delta function gives

$$y = \frac{m}{2(\omega_1 + \omega_2)}, \quad z' = \frac{z_1 \omega_1 + z_2 \omega_2}{\omega_1 + \omega_2}, \quad \bar{z}' = \frac{\bar{z}_1 \omega_1 + \bar{z}_2 \omega_2}{\omega_1 + \omega_2}, \quad \omega_1 \omega_2 = \frac{m^2}{4|z_{12}|^2}, \quad (145)$$

and the Jacobian

$$|\text{Jacobian}| = \frac{8m|z_{12}|^4 \omega_2^2}{(m^2 + 4|z_{12}|^2 \omega_2^2)^3}. \quad (146)$$

The inner products that appear in the $(p_{12} \cdot K)^J G_{\ell, \Delta}^{(J)}(\hat{k}, Y; z, \bar{z})$ are summarized as

$$\begin{aligned} 2p_{12} \cdot q &= -4|z - z_2|^2 \omega_2 + \frac{m^2 |z - z_1|^2}{|z_{12}|^2 \omega_2}, \quad 2k \cdot q = -4|z - z_2|^2 \omega_2 - \frac{m^2 |z - z_1|^2}{|z_{12}|^2 \omega_2}, \\ p_{12}^2 &= m^2, \quad k \cdot p_{12} = 0, \\ (k \cdot q)(p_{12} \cdot \partial_{\bar{z}} q) - (k \cdot \partial_{\bar{z}} q)(q \cdot p_{12}) &= -\frac{2m(z - z_1)(z - z_2)}{z_{12}}. \end{aligned} \quad (147)$$

We find

$$p_{12} \cdot K = \left(N_Y + \frac{1}{2}\right) p_{12} \cdot \partial_Y - \frac{1}{2} (p_{12} \cdot Y) (\partial_Y^2 + (\hat{k} \cdot \partial_Y)^2), \quad (148)$$

where $N_Y = Y \cdot \partial_Y$ simply counts the number of Y . We have the following identities

$$\begin{aligned} \partial_Y^2 G_{\ell, \Delta}^{(J)}(\hat{k}, Y; z, \bar{z}) &= 0, \\ (\hat{k} \cdot \partial_Y)^2 G_{\ell, \Delta}^{(J)}(\hat{k}, Y; z, \bar{z}) &= (J - |\ell|)(J - |\ell| - 1) G_{\ell, \Delta}^{(J-2)}(\hat{k}, Y; z, \bar{z}). \end{aligned} \quad (149)$$

Using these formulae, we find

$$\begin{aligned}
 & (p_{12} \cdot K)^J G_{\ell, \Delta}^{(J)}(\hat{k}, Y; z, \bar{z}) \Big|_{Y=0} \\
 &= \frac{1}{2^J} \sum_{n=0}^{\frac{J}{2}} (-1)^n (2J-1-2n)!! (2n-1)!! \binom{J}{2n} \\
 & \quad \times m^{2n} (p_{12} \cdot \partial_Y)^{J-2n} (\hat{k}_{12} \cdot \partial_Y)^{2n} G_{\ell, \Delta}^{(J)}(\hat{k}, Y; z, \bar{z}) \Big|_{Y=0} \\
 &= \frac{1}{2^J} \sum_{n=0}^{\frac{J}{2}} (-1)^n (2J-1-2n)!! (2n-1)!! \binom{J}{2n} \\
 & \quad \times m^{2n} \frac{(J-|\ell|)!(J-2n)!}{(J-|\ell|-2n)!} G_{\ell, \Delta}^{(J-2n)}(\hat{k}, p_{12}, z, \bar{z}).
 \end{aligned} \tag{150}$$

Let us assume $\ell \geq 0$, and consider the integral

$$\begin{aligned}
 & \left(\prod_{i=1}^2 \int_0^\infty d\omega_i \omega_i^{\Delta_i-1} \right) \int \frac{dy}{y^3} dz' d\bar{z}' \delta^4(p+p_1+p_2) G_{\ell, \Delta}^{(J-2n)}(\hat{k}, p_{12}; z, \bar{z}) \\
 &= 2^{2-\Delta_1-\Delta_2-\Delta} m^{\Delta_1+\Delta_2-4+J-2n} |z_{12}|^{-2\Delta_1} \left(\frac{(z-z_1)(z-z_2)}{z_{12}} \right)^\ell \frac{1}{|z-z_2|^{2(\Delta+\ell)}} \\
 & \quad \times \int_0^\infty d\omega_2 \sum_{p=0}^{J-2n-\ell} (-1)^{\ell+p} \binom{J-2n-\ell}{p} \frac{\omega_2^{\Delta_2-\Delta_1-1+\Delta+\ell+2p} \left(\frac{|z-z_1|^2}{|z_{12}|^2|z-z_2|^2} \right)^{J-2n-\ell-p}}{\left(\omega_2^2 + \frac{|z-z_1|^2}{|z_{12}|^2|z-z_2|^2} \right)^{\Delta+J-2n}} \\
 &= 2^{1-\Delta_1-\Delta_2-\Delta} m^{\Delta_1+\Delta_2-4+J-2n} \sum_{p=0}^{J-2n-\ell} (-1)^{\ell+p} \binom{J-2n-\ell}{p} \\
 & \quad \times B\left(\frac{\Delta+\ell+2p-\Delta_1+\Delta_2}{2}, \frac{\Delta-\ell+2J-4n-2p+\Delta_1-\Delta_2}{2} \right) \\
 & \quad \times \left(\frac{(z-z_1)(z-z_2)}{z_{12}} \right)^\ell |z-z_1|^{\Delta_2-\Delta_1-\Delta-\ell} |z-z_2|^{\Delta_1-\Delta_2-\Delta-\ell} |z_{12}|^{\Delta+\ell-\Delta_1-\Delta_2}.
 \end{aligned} \tag{151}$$

The three-point coefficient is

$$\begin{aligned}
 C_{\Delta_1, \Delta_2; \Delta, \ell}^{(J)} &= \frac{m^{\Delta_1+\Delta_2-4+J}}{2^{\Delta_1+\Delta_2+\Delta+J-1} J! \left(\frac{1}{2}\right)_J} \sum_{n=0}^{\frac{J}{2}} \sum_{p=0}^{J-2n-\ell} (-1)^{\ell+n+p} \binom{J}{2n} \binom{J-2n-\ell}{p} \\
 & \quad \times \frac{(J-|\ell|)!(J-2n)!(2J-1-2n)!!(2n-1)!!}{(J-|\ell|-2n)!} \\
 & \quad \times B\left(\frac{\Delta+\ell+2p-\Delta_1+\Delta_2}{2}, \frac{\Delta-\ell+2J-4n-2p+\Delta_1-\Delta_2}{2} \right).
 \end{aligned} \tag{152}$$

References

- [1] S. Pasterski, S.-H. Shao and A. Strominger, *Flat space amplitudes and conformal symmetry of the celestial sphere*, Phys. Rev. D **96**, 065026 (2017), doi:[10.1103/PhysRevD.96.065026](https://doi.org/10.1103/PhysRevD.96.065026).
- [2] C. Cardona and Y.-t. Huang, *S-matrix singularities and CFT correlation functions*, J. High Energy Phys. **08**, 133 (2017), doi:[10.1007/JHEP08\(2017\)133](https://doi.org/10.1007/JHEP08(2017)133).

- [3] A. Strominger, *Lectures on the infrared structure of gravity and gauge theory*, [arXiv:1703.05448](https://arxiv.org/abs/1703.05448).
- [4] S. Pasterski and S.-H. Shao, *Conformal basis for flat space amplitudes*, *Phys. Rev. D* **96**, 065022 (2017), doi:[10.1103/PhysRevD.96.065022](https://doi.org/10.1103/PhysRevD.96.065022).
- [5] S. Pasterski, S.-H. Shao and A. Strominger, *Gluon amplitudes as 2d conformal correlators*, *Phys. Rev. D* **96**, 085006 (2017), doi:[10.1103/PhysRevD.96.085006](https://doi.org/10.1103/PhysRevD.96.085006).
- [6] H. T. Lam and S.-H. Shao, *Conformal basis, optical theorem, and the bulk point singularity*, *Phys. Rev. D* **98**, 025020 (2018), doi:[10.1103/PhysRevD.98.025020](https://doi.org/10.1103/PhysRevD.98.025020).
- [7] N. Banerjee, S. Banerjee, S. A. Bhatkar and S. Jain, *Conformal structure of massless scalar amplitudes beyond tree level*, *J. High Energy Phys.* **04**, 039 (2018), doi:[10.1007/JHEP04\(2018\)039](https://doi.org/10.1007/JHEP04(2018)039).
- [8] A. Schreiber, A. Volovich and M. Zlotnikov, *Tree-level gluon amplitudes on the celestial sphere*, *Phys. Lett. B* **781**, 349 (2018), doi:[10.1016/j.physletb.2018.04.010](https://doi.org/10.1016/j.physletb.2018.04.010).
- [9] S. Banerjee, *Null infinity and unitary representation of the Poincaré group*, *J. High Energy Phys.* **01**, 205 (2019), doi:[10.1007/JHEP01\(2019\)205](https://doi.org/10.1007/JHEP01(2019)205).
- [10] S. Stieberger and T. R. Taylor, *Strings on celestial sphere*, *Nucl. Phys. B* **935**, 388 (2018), doi:[10.1016/j.nuclphysb.2018.08.019](https://doi.org/10.1016/j.nuclphysb.2018.08.019).
- [11] L. Donnay, A. Puhm and A. Strominger, *Conformally soft photons and gravitons*, *J. High Energy Phys.* **01**, 184 (2019), doi:[10.1007/JHEP01\(2019\)184](https://doi.org/10.1007/JHEP01(2019)184).
- [12] S. Stieberger and T. R. Taylor, *Symmetries of celestial amplitudes*, *Phys. Lett. B* **793**, 141 (2019), doi:[10.1016/j.physletb.2019.03.063](https://doi.org/10.1016/j.physletb.2019.03.063).
- [13] S. Banerjee, P. Pandey and P. Paul, *Conformal properties of soft operators: Use of null states*, *Phys. Rev. D* **101**, 106014 (2020), doi:[10.1103/PhysRevD.101.106014](https://doi.org/10.1103/PhysRevD.101.106014).
- [14] W. Fan, A. Fotopoulos and T. R. Taylor, *Soft limits of Yang-Mills amplitudes and conformal correlators*, *J. High Energy Phys.* **05**, 121 (2019), doi:[10.1007/JHEP05\(2019\)121](https://doi.org/10.1007/JHEP05(2019)121).
- [15] M. Pate, A.-M. Raclariu and A. Strominger, *Conformally soft theorem in gauge theory*, *Phys. Rev. D* **100**, 085017 (2019), doi:[10.1103/PhysRevD.100.085017](https://doi.org/10.1103/PhysRevD.100.085017).
- [16] A. Puhm, *Conformally soft theorem in gravity*, *J. High Energy Phys.* **09**, 130 (2020), doi:[10.1007/JHEP09\(2020\)130](https://doi.org/10.1007/JHEP09(2020)130).
- [17] Y. T. A. Law and M. Zlotnikov, *Poincaré constraints on celestial amplitudes*, *J. High Energy Phys.* **03**, 085 (2020), doi:[10.1007/JHEP03\(2020\)085](https://doi.org/10.1007/JHEP03(2020)085).
- [18] M. Pate, A.-M. Raclariu, A. Strominger and E. Y. Yuan, *Celestial operator products of gluons and gravitons*, *Rev. Math. Phys.* **33**, 21400031 (2021), doi:[10.1142/S0129055X21400031](https://doi.org/10.1142/S0129055X21400031).
- [19] L. Donnay, S. Pasterski and A. Puhm, *Asymptotic symmetries and celestial CFT*, *J. High Energy Phys.* **09**, 176 (2020), doi:[10.1007/JHEP09\(2020\)176](https://doi.org/10.1007/JHEP09(2020)176).
- [20] Y. T. A. Law and M. Zlotnikov, *Relativistic partial waves for celestial amplitudes*, *J. High Energy Phys.* **11**, 149 (2020), doi:[10.1007/JHEP11\(2020\)149](https://doi.org/10.1007/JHEP11(2020)149).

- [21] N. Arkani-Hamed, M. Pate, A.-M. Raclariu and A. Strominger, *Celestial amplitudes from UV to IR*, J. High Energy Phys. **08**, 062 (2021), doi:[10.1007/JHEP08\(2021\)062](https://doi.org/10.1007/JHEP08(2021)062).
- [22] D. Nandan, A. Schreiber, A. Volovich and M. Zlotnikov, *Celestial amplitudes: Conformal partial waves and soft limits*, J. High Energy Phys. **10**, 018 (2019), doi:[10.1007/JHEP10\(2019\)018](https://doi.org/10.1007/JHEP10(2019)018).
- [23] N. Arkani-Hamed, T.-C. Huang and Y.-t. Huang, *The EFT-hedron*, J. High Energy Phys. 259 (2021), doi:[10.1007/JHEP05\(2021\)259](https://doi.org/10.1007/JHEP05(2021)259).
- [24] J.-Y. Liu and Z.-M. You, *The supersymmetric spinning polynomial*, [arXiv:2011.11299](https://arxiv.org/abs/2011.11299).
- [25] B. Bellazzini, J. E. Miró, R. Rattazzi, M. Riembau and F. Riva, *Positive moments for scattering amplitudes*, Phys. Rev. D **104**, 036006 (2021), doi:[10.1103/PhysRevD.104.036006](https://doi.org/10.1103/PhysRevD.104.036006).
- [26] A. J. Tolley, Z.-Y. Wang and S.-Y. Zhou, *New positivity bounds from full crossing symmetry*, J. High Energy Phys. 255 (2021) doi:[10.1007/JHEP05\(2021\)255](https://doi.org/10.1007/JHEP05(2021)255).
- [27] S. Caron-Huot and V. Van Duong, *Extremal effective field theories*, J. High Energy Phys. **05**, 280 (2021), doi:[10.1007/JHEP05\(2021\)280](https://doi.org/10.1007/JHEP05(2021)280).
- [28] S. Caron-Huot, D. Mazáč, L. Rastelli and D. Simmons-Duffin, *Sharp boundaries for the swampland*, J. High Energy Phys. **07**, 110 (2021), doi:[10.1007/JHEP07\(2021\)110](https://doi.org/10.1007/JHEP07(2021)110).
- [29] A. B. Zamolodchikov, *Conformal symmetry in two dimensions: An explicit recurrence formula for the conformal partial wave amplitude*, Commun. Math. Phys. **96**, 419 (1984), doi:[10.1007/BF01214585](https://doi.org/10.1007/BF01214585).
- [30] A. Zamolodchikov and Al. Zamolodchikov, *Conformal bootstrap in Liouville field theory*, Nucl. Phys. B **477**, 577 (1996), doi:[10.1016/0550-3213\(96\)00351-3](https://doi.org/10.1016/0550-3213(96)00351-3).
- [31] J. Penedones, E. Trevisani and M. Yamazaki, *Recursion relations for conformal blocks*, J. High Energy Phys. **09**, 070 (2016), doi:[10.1007/JHEP09\(2016\)070](https://doi.org/10.1007/JHEP09(2016)070).
- [32] J. Murugan, D. Stanford and E. Witten, *More on supersymmetric and 2d analogs of the SYK model*, J. High Energy Phys. **08**, 146 (2017), doi:[10.1007/JHEP08\(2017\)146](https://doi.org/10.1007/JHEP08(2017)146).
- [33] D. Simmons-Duffin, D. Stanford and E. Witten, *A spacetime derivation of the Lorentzian OPE inversion formula*, J. High Energy Phys. **07**, 085 (2018), doi:[10.1007/JHEP07\(2018\)085](https://doi.org/10.1007/JHEP07(2018)085).
- [34] Y. T. A. Law and M. Zlotnikov, *Massive spinning bosons on the celestial sphere*, J. High Energy Phys. **06**, 079 (2020), doi:[10.1007/JHEP06\(2020\)079](https://doi.org/10.1007/JHEP06(2020)079).