

Mixed QCD-electroweak corrections to Z and W boson production and their impact on the W mass measurements at the LHC

A. Behring*

Institute for Theoretical Particle Physics, KIT, Karlsruhe, Germany

* arnd.behring@cern.ch



15th International Symposium on Radiative Corrections:
Applications of Quantum Field Theory to Phenomenology,
FSU, Tallahassee, FL, USA, 17-21 May 2021
doi:[10.21468/SciPostPhysProc.7](https://doi.org/10.21468/SciPostPhysProc.7)

Abstract

We report on recently computed mixed QCD-electroweak corrections to on-shell W and Z boson production. We use these differential predictions to estimate their impact on the W boson mass determination at the LHC.



Copyright A. Behring.

This work is licensed under the Creative Commons

[Attribution 4.0 International License](https://creativecommons.org/licenses/by/4.0/).

Published by the SciPost Foundation.

Received 30-11-2021

Accepted 28-02-2022

Published 20-06-2022

doi:[10.21468/ciPostPhysProc.7.003](https://doi.org/10.21468/ciPostPhysProc.7.003)



Check for updates

1 Introduction

The mass of the W boson, m_W , has been measured with very high precision at both lepton and hadron colliders. The most recent measurement by the ATLAS collaboration [1] quotes an uncertainty of 19 MeV, which can be compared to 8 MeV uncertainty from global electroweak fits [2, 3]. A very precise knowledge of this and other Standard Model parameters allows to cross-check the internal consistency of the Standard Model and to search for hints of new physics. CMS and ATLAS aim to further reduce the uncertainty to about $\mathcal{O}(10\text{MeV})$ which would rival the precision from global electroweak fits. This corresponds to an astounding precision of about 0.01%.

In order to measure the W boson mass at a hadron collider, one can use on-shell production of a single vector boson and its subsequent decay into leptons, i.e., $pp \rightarrow W \rightarrow \ell \nu$. Of course we then need observables which are sensitive to m_W . Two classic examples of such observables are the transverse mass of the W boson, $m_{\perp}^{\ell \nu}$, and the transverse momentum of the charged lepton from the decay of the W boson, p_{\perp}^{ℓ} . Both observables have the appealing feature that in the absence of higher-order corrections and with an ideal detector (and very narrow W width) the distributions of these observables have sharp kinematic edges (at $m_{\perp}^{\ell \nu} = m_W$ and $p_{\perp}^{\ell} = m_W/2$, respectively) that would be easy to measure precisely. These edges get washed

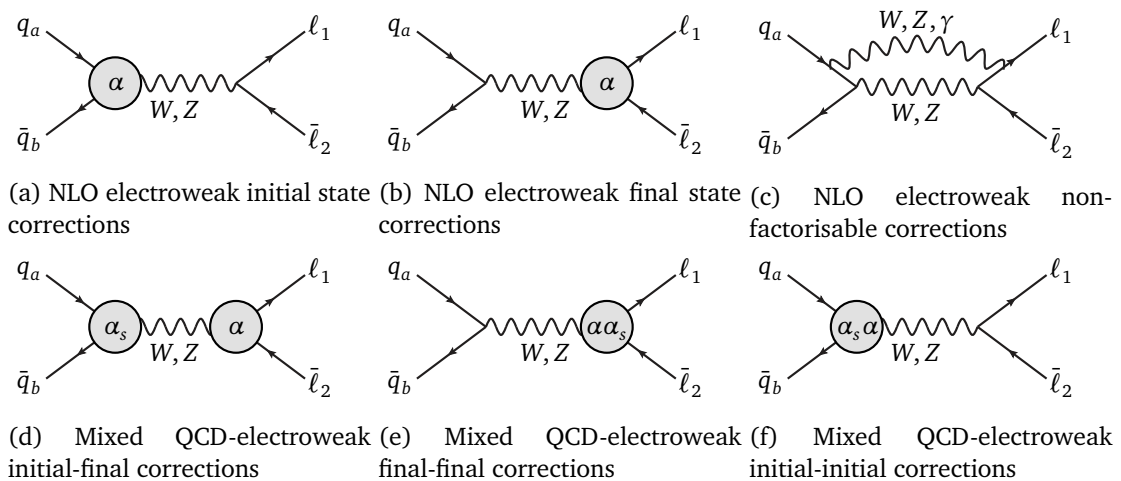

Figure 1: Schematic Feynman diagrams illustrating the different types of contributions to the single vector boson production process.

out by detector effects in the case of the transverse mass and by higher-order corrections in the case of the transverse momentum. This makes the two observables complementary since in the former case the issue is mostly an experimental one while in the latter case the distribution can be measured very precisely while more involved theory predictions are necessary to extract m_W .

The very high target precision for the W boson mass means that we also have to reconsider the approach by which we deal with the theory predictions. The standard tools (collinear factorisation, fixed-order perturbation theory, resummation, parton showers...) usually let us reach uncertainties at the 1% level. We cannot hope to predict kinematic distributions at a level of $\mathcal{O}(0.01\%)$ uncertainty from first principles. As a way out, we can combine measurements of W and Z boson production, parametrise the Z distributions in a QCD-motivated way and transfer them to W distributions, arguing that the bulk of QCD does not distinguish between W and Z bosons. This means that we have to focus on modelling effects that do distinguish between W and Z boson production to the desired level of accuracy. However, this also implies that we have to take into account effects that were previously deemed irrelevant. One such example would obviously be electroweak corrections.

For the goal of measuring m_W , we deal with on-shell W and Z boson production, which allows us to use the narrow width approximation. Since then the production and decay processes factorise, also the corrections can be classified as corrections to the initial or the final state. At NLO QCD corrections can only occur on the initial state, while NLO electroweak corrections affect both the initial and final state (Figs. 1a and 1b). In principle, there are also non-factorising corrections where the initial and final state exchange a W , Z or photon (Fig. 1c), but it has been shown [4] that these corrections are suppressed by Γ_V/m_V , which parametrically corresponds to another power of α . At the next order of perturbation theory, we can have mixed QCD-electroweak corrections for the first time. They can again be classified according to which part of the process receives corrections. The initial-final (Fig. 1d) and final-final (Fig. 1e) corrections either factorise into NLO \otimes NLO corrections or are only due to renormalisation contributions, respectively, and they have been dealt with in Refs. [5,6]. There it was estimated that they can amount to a shift in the m_W measurement of about 15 MeV. On the other hand, the initial-initial corrections (Fig. 1d) require a genuine NNLO-type calculation and have not been known until recently. They have generated a lot of activity, especially in the in the past few years [7–15], and they are the subject of this proceedings contribution and the papers on which it is based [16–19].

A number of building blocks are required to complete the initial-initial mixed QCD-electroweak corrections to weak gauge boson production. We need amplitudes at tree-level with up to two additional emissions of a photon and/or a gluon, one-loop amplitudes with one emission and finally also the two-loop form factors for on-shell W and Z bosons. Moreover, since the additional emissions of massless bosons lead to infrared singularities if those particles become soft or collinear to other massless partons, we have to use an NNLO subtraction scheme to isolate the divergences and cancel them against the divergences from virtual corrections. We adapt the nested soft-collinear subtraction scheme, which was developed for NNLO QCD calculations, to QCD-electroweak corrections. In the following, we briefly highlight two aspects of the calculation, the two-loop on-shell W boson form factor as well as the subtraction scheme, before discussing the results for the W mass measurements.

2 Two-loop amplitudes

Since we work in the narrow-width approximation, we need the two-loop on-shell form factors for W and Z productions. This is a simplification compared to the more general off-shell case where also complicated two-loop four-point functions are required (see [20–23] for some recent developments). The mixed QCD-EW corrections to the on-shell form factor for Z boson production have already been known for over a decade [24]. For W production, to the best of our knowledge, the form factor has not been publicly available. Therefore, we have calculated the missing integrals and completed the form factor.

For the W boson form factor, we have to calculate 44 Feynman diagrams which we reduce via integration-by-parts relations to 35 master integrals. Of those integrals 25 are already available in the literature [20, 25, 26]. They all fall into the category where there is at most one internal mass, i.e., when there are only either W or Z bosons on internal lines. These integrals are sufficient to calculate the Z boson form factor. Additionally, the W boson form factor requires 10 integrals in which W and Z bosons appear on internal lines simultaneously and which were not available in the literature.

In order to calculate them, we derived differential equations in the mass ratio $z = m_W^2/m_Z^2$,

$$\frac{d}{dz}I(z, \epsilon) = A(z, \epsilon)I(z, \epsilon), \tag{1}$$

and use the equal mass case, $z = 1$, as boundary conditions. The required boundary constants then fall into the class of integrals that are already available in the literature.

The differential equation can be solved in terms of GPLs if we use the rational variable transformation $z = \frac{y}{(1+y)^2}$. An even more compact representation of the result can be found if we use the original mass ratio variable z and iterated integrals, defined recursively via

$$H_{a,\bar{b}}(z) = \int_0^z f_a(t)H_{\bar{b}}(t)dt, \quad H_{\emptyset}(z) = 1, \quad \underbrace{H_{0,\dots,0}}_{n \text{ times}}(z) = \frac{\ln^n(z)}{n!}, \tag{2}$$

over the alphabet

$$f_1(t) = \frac{1}{1-t}, \quad f_0(t) = \frac{1}{t}, \quad f_{-1}(t) = \frac{1}{1+t}, \quad f_r(t) = \frac{1}{\sqrt{t(4-t)}}. \tag{3}$$

We presented the result for the form factor in Appendix B of Ref. [18].

3 Subtraction scheme

Fixed-order calculations beyond tree level develop infrared singularities in real corrections which lead to $1/\epsilon$ poles after integrating over the phase space and which cancel against corresponding poles in the virtual corrections. Since the phase space integration is often carried out numerically, e.g., to include non-trivial phase space constraints, the infrared poles have to be extracted and cancelled before numerical integration becomes possible. A common way to do that is to use subtraction schemes. The basic idea of this method is to introduce a term that behaves exactly like the infrared singularity in singular regions of phase space but which can still be integrated explicitly. By subtracting this term, singularities of real-emission matrix elements become regulated. This part can be integrated numerically. In the second part, one adds back the subtracted term and integrates it explicitly over the singular phase space region, thereby exposing the $1/\epsilon$ poles. Since we add and subtract the same term, the overall expression stays unchanged. There has been a lot of progress with NNLO subtraction schemes for QCD over the past decade. We build on this progress by adapting the nested-soft collinear subtraction scheme [27–30] to mixed QCD-electroweak corrections. For the Z boson, it is sufficient to take an implementation of the subtraction scheme for NNLO QCD corrections and to replace colour factors according to simple abelianisation rules [7, 16]. For the W boson, on the other hand, new contributions arise due to the fact that W bosons can radiate photons which in turn gives rise to new types of infrared singularities compared to the NNLO QCD case.

However, we also profit from simplifications in mixed QCD-electroweak corrections compared to NNLO QCD. One such example are the triple collinear limits, which have overlapping singularities in NNLO QCD due to the fact that the two emitted partons can become collinear at different rates: the parton emitted earlier can become collinear to the emitting parton faster than the parton emitted later or vice versa, or they can become collinear to each first and only then collinear to the emitting parton. In the original formulation of the nested soft-collinear subtraction scheme, four sectors are introduced to disentangle these singularities. In the mixed QCD-electroweak case, when a gluon and a photon are emitted, the collinear limit of these two bosons does not give rise to a singularity. Therefore, we can drop two sectors and thereby simplify the construction. Moreover, no new collinear limits arise in the mixed QCD-electroweak case compared to NNLO QCD.

An even more dramatic simplification occurs in the double-soft limit. At NNLO in QCD the double-soft eikonal function has non-trivial overlapping singularities due to the fact that the emitted partons can become soft at different rates. One way to deal with this is to introduce an energy ordering by inserting a partition of unity via $1 = \theta(E_{g_1} - E_{g_2}) + \theta(E_{g_2} - E_{g_1})$, where E_{g_1} and E_{g_2} are the energies of the two gluons, respectively, and then use different sector decomposition transformations in each of the two sectors. However, for mixed QCD-electroweak corrections, soft photons and soft gluons are not entangled and the double-soft limit factorises into a NLO QCD part and a NLO QED part. As an example, if we take the squared matrix element for W production with the emission of a gluon and a photon, $|\mathcal{M}_{Wg\gamma}|^2$, and take the soft limit of the gluon and photon, we obtain

$$\lim_{E_g, E_\gamma \rightarrow 0} |\mathcal{M}_{Wg\gamma}|^2 \simeq g_s^2 \text{Eik}_g(p_u, p_{\bar{d}}; p_g) e^2 \text{Eik}_\gamma(p_u, p_{\bar{d}}, p_W; p_\gamma) |\mathcal{M}_W|^2, \quad (4)$$

where $|\mathcal{M}_W|^2$ is the squared matrix element for W production and the QCD soft eikonal function reads

$$\text{Eik}_g(p_u, p_{\bar{d}}; p_g) = 2C_F \frac{(p_u \cdot p_{\bar{d}})}{(p_u \cdot p_g)(p_g \cdot p_{\bar{d}})}. \quad (5)$$

Thus, there is no need to distinguish whether the gluon or the photon becomes soft faster and we do not have to introduce an energy ordering. This simplifies the soft limits tremendously.

The fact that the W boson is electrically charged and, therefore, can radiate photons, leads to new contributions that do not have a correspondence in the NNLO QCD calculation. The mass of the W boson screens against collinear singularities from this photon, but the photon can still become soft and cause a singularity that way. To construct a subtraction term for this limit, we need the soft eikonal function for massive emitters. But since QCD and QED factorise in the soft limit, as discussed above, only NLO eikonal functions are necessary. The corresponding NLO QED soft eikonal function reads

$$\text{Eik}_\gamma(p_u, p_{\bar{d}}, p_W; p_\gamma) = \left\{ Q_u Q_d \frac{2(p_u \cdot p_{\bar{d}})}{(p_u \cdot p_\gamma)(p_{\bar{d}} \cdot p_\gamma)} - Q_W^2 \frac{p_W^2}{(p_W \cdot p_\gamma)^2} + Q_W \left(Q_u \frac{2(p_W \cdot p_u)}{(p_W \cdot p_\gamma)(p_u \cdot p_\gamma)} - Q_d \frac{2(p_W \cdot p_{\bar{d}})}{(p_W \cdot p_\gamma)(p_{\bar{d}} \cdot p_\gamma)} \right) \right\}. \quad (6)$$

More details about the subtraction scheme for mixed QCD-electroweak corrections to on-shell W production are presented in Ref. [18].

4 Estimates of the impact of mixed corrections on the W mass

Once all required building blocks are available it becomes possible to calculate fiducial cross sections and differential distributions for on-shell W and Z boson production. In Refs. [17, 18] it was shown that mixed QCD-electroweak corrections to these processes are very small, about $\mathcal{O}(0.05\%)$, but not obviously irrelevant for m_W measurements at the LHC. Therefore, it is interesting to *estimate* the impact of the *newly-computed* initial-initial mixed QCD-electroweak corrections on the W boson mass measurements. There were a number of considerations that guided us when we devised how to derive these estimates:

- The method should combine W and Z measurements, since, as discussed above, this models what is being done in experimental analyses and also makes use of the precision that is available for the Z mass measurements at LEP.
- The method should be physically and conceptually simple and transparent. The experimental collaborations use an intricate template-fit-based method which would require a careful implementation of all relevant effects besides the new corrections.
- The method should be accessible with our calculations. Since we work in fixed-order perturbation theory and employ the narrow-width approximation, we cannot use the transverse mass as it is sensitive to off-shell effects which are not appropriately captured by this description. Instead, we use the transverse momentum distribution of the charged lepton below.

Let us stress again that the goal here is to derive estimates for the shifts caused by these particular corrections and not to assess all possible effects or to propose this method for performing the measurement.

We use the average transverse momentum of the charged lepton from the decay of the weak gauge boson ($V = W, Z$), calculated according to

$$\langle p_\perp^{\ell, V} \rangle = \frac{\int d\sigma_V \times p_\perp^\ell}{\int d\sigma_V}, \quad (7)$$

where the phase space integration may be subject to constraints, e.g., from fiducial cuts. Thus, we effectively calculate the first moment of the p_\perp^ℓ distribution normalised to the fiducial cross

Table 1: Estimates for the shifts of m_W due to the NLO electroweak and the mixed QCD-electroweak corrections for different values of the factorisation and renormalisation scales $\mu = \mu_R = \mu_F$. For details on the three sets of fiducial cuts (“inclusive”, “fiducial” and “tuned fiducial”) see the main text.

δm_W [MeV]		$\mu = m_V/4$	$\mu = m_V/2$	$\mu = m_V$
Inclusive	NLO EW	−0.1	0.3	0.2
	QCD-EW	−5.1	−7.5	−9.3
Fiducial	NLO EW	0.2	2.3	4.2
	QCD-EW	−16	−17	−19
Tuned fiducial	NLO EW	−4.4	−2.5	−0.8
	QCD-EW	3.9	−1.0	−5.7

section. Since the p_{\perp}^{ℓ} distribution has a peak, which results from the smeared edge at $p_{\perp}^{\ell} = \frac{m_V}{2}$, the first moment is of course highly sensitive to the value of m_V . At leading order, when the only cut on the final state is a minimal p_{\perp}^{ℓ} , the observable takes the form

$$\langle p_{\perp}^{\ell,V} \rangle = m_V f\left(\frac{p_{\perp}^{\text{cut}}}{m_V}\right), \quad \text{with } f(r) = \frac{3}{32} \frac{r(5-8r^2)}{1-r^2} + \frac{15}{64} \frac{\arcsin(\sqrt{1-4r^2})}{(1-r^2)\sqrt{1-4r^2}}. \quad (8)$$

This illustrates that there is a strong dependence of the observable on the vector boson mass. If we ignore the influence of the cut ($f(p_{\perp}^{\text{cut}}/m_V)$) the dependence is linear. With this in mind, we now construct the observable

$$m_W^{\text{meas}} = \frac{\langle p_{\perp}^{\ell,W} \rangle^{\text{meas}}}{\langle p_{\perp}^{\ell,Z} \rangle^{\text{meas}}} m_Z C_{\text{th}}. \quad (9)$$

The average lepton transverse momenta $\langle p_{\perp}^{\ell,V} \rangle$ are taken as measurements from the LHC. As we just discussed, they each are proportional to m_V . The Z boson mass m_Z is taken from the measurements at LEP, making use of the precision that is available from there. Finally, there is a theoretical correction factor C_{th} , which models all the details that distinguish between W and Z bosons, including, for example, different fiducial cuts in both cases. The theoretical correction factor can be calculated by solving Eq. (9) for C_{th} and replacing $\langle p_{\perp}^{\ell,V} \rangle^{\text{meas}}$ by theory calculations, i.e.,

$$C_{\text{th}} = \frac{m_W}{m_Z} \frac{\langle p_{\perp}^{\ell,Z} \rangle^{\text{th}}}{\langle p_{\perp}^{\ell,W} \rangle^{\text{th}}}. \quad (10)$$

Therefore, if we add a new contribution, like the mixed QCD-electroweak corrections, to the theory, the value of C_{th} changes and hence also the extracted W boson mass m_W^{meas} . In order to quantify the size of the shift induced by the new correction, we have to use

$$\frac{\delta m_W^{\text{meas}}}{m_W^{\text{meas}}} = \frac{\delta C_{\text{th}}}{C_{\text{th}}} = \frac{\delta \langle p_{\perp}^{\ell,Z} \rangle}{\langle p_{\perp}^{\ell,Z} \rangle} - \frac{\delta \langle p_{\perp}^{\ell,W} \rangle}{\langle p_{\perp}^{\ell,W} \rangle}. \quad (11)$$

The last step also highlights the fact that the shift of m_W is sensitive to differences between the W and Z boson cases: if the observable changes in exactly the same way in both cases, the change cancels out in the final shift.

If we use Eq. (11) to derive estimates for the shift of the measured value of the W boson mass due to the inclusion of NLO electroweak or mixed QCD-electroweak corrections, we find

the results presented in table Table 1. If we consider the inclusive case, i.e., we do not impose any cuts, we find shifts of about -7 MeV for the mixed QCD-electroweak corrections. These are much larger than the shifts induced by the NLO electroweak corrections, which are below 1 MeV. One reason for this is that the NLO electroweak corrections are particularly small due to our choice to work in the G_μ input parameter scheme, which is known to reduce the size of NLO electroweak corrections in Drell-Yan-type processes. The other reason is a strong cancellation between the changes in the W and the Z boson cases. To illustrate this point, we have also calculated the shifts that would arise if we artificially set $\delta\langle p_\perp^{\ell,Z} \rangle$ to zero. Then we would find $\delta m_W \approx -31$ MeV for NLO electroweak corrections and $\delta m_W \approx 54$ MeV for mixed QCD-electroweak corrections. Comparing these values to the results in the table, we see that there is a particularly strong cancellation between $\langle p_\perp^{\ell,Z} \rangle$ and $\langle p_\perp^{\ell,W} \rangle$ for NLO electroweak corrections.

The qualitative picture remains the same if we apply fiducial cuts to both the W and the Z boson observables. However, the size of corrections increases by about a factor 2.5. The cuts are inspired by the ATLAS analysis [1] and involve, among other things, a cut on the transverse momentum of the charged leptons: $p_\perp^{e^\pm} > 30$ GeV for W production and $p_\perp^{e^\pm} > 25$ GeV for Z production. This difference is sufficient to explain the larger size of the shifts in this setup. The average transverse momentum is sensitive to the ratio p_\perp^{cut}/m_V , as can also be seen in Eq. (8). However, ATLAS applies larger cuts on p_\perp for W production than for Z production, while the Z boson is of course heavier than the W boson. This leads to a decorrelation between the W and Z boson observables and therefore disturbs the cancellation in Eq. (11).

Since the size of the shifts strongly depends on the fiducial cuts, we can also try to use this to “tune” the cuts such that the size of the mixed QCD-electroweak corrections is minimised. The results in Table 1 for the “tuned fiducial” setup show that this is indeed possible. We start from the same cuts as in the “fiducial” setup and adjust the cut on $p_\perp^{e^+}$ for W production such that $C_{\text{th}} = 1$ at leading order. To achieve this, we have to require $p_\perp^{e^+} > 25.44$ GeV for W production. With these cuts, the impact of the mixed QCD-electroweak corrections gets substantially reduced. This serves to show that fiducial cuts are an important factor when assessing the impact of mixed QCD-electroweak corrections.

5 Conclusion

We have calculated the mixed QCD-electroweak corrections to fully-differential on-shell W and Z production at the LHC. This became possible due to progress on amplitude calculations and subtraction schemes. We found that these corrections are small, in line with the expectations, but they are not obviously irrelevant for the W boson mass measurements. Since experimental measurements of m_W rely on the similarity of W and Z distributions, we have built a simple model to estimate shifts on m_W using the average transverse momentum of the charged leptons. We find that the mixed QCD-electroweak corrections induce shifts on m_W that are comparable to or even larger than the target precision of $\mathcal{O}(10$ MeV). Moreover, the size of the shifts is strongly dependent on the fiducial cuts. Further investigations on the impact of mixed QCD-electroweak corrections to m_W are clearly warranted, and they should reflect all relevant details of the experimental analyses.

Acknowledgements

The author would like to thank F. Buccioni, F. Caola, M. Delto, M. Jaquier, K. Melnikov and R. Röntsch for the fruitful collaboration on the topic on which the results in this article are

based as well as K. Melnikov for comments on the manuscript.

Funding information This research is partially supported by the Deutsche Forschungsgemeinschaft (DFG, German Research Foundation) under grant 396021762 - TRR 257.

References

- [1] M. Aaboud et al., *Measurement of the W-boson mass in pp collisions at $\sqrt{s} = 7$ TeV with the ATLAS detector*, Eur. Phys. J. C **78**, 110 (2018), doi:[10.1140/epjc/s10052-017-5475-4](https://doi.org/10.1140/epjc/s10052-017-5475-4), [Erratum: Eur. Phys. J. C **78**, 898 (2018)].
- [2] M. Baak et al., *The global electroweak fit at NNLO and prospects for the LHC and ILC*, Eur. Phys. J. C **74**, 3046 (2014), doi:[10.1140/epjc/s10052-014-3046-5](https://doi.org/10.1140/epjc/s10052-014-3046-5).
- [3] J. de Blas, M. Ciuchini, E. Franco, S. Mishima, M. Pierini, L. Reina and L. Silvestrini, *Electroweak precision observables and Higgs-boson signal strengths in the Standard Model and beyond: present and future*, J. High Energy Phys. **12**, 135 (2016), doi:[10.1007/JHEP12\(2016\)135](https://doi.org/10.1007/JHEP12(2016)135).
- [4] S. Dittmaier, A. Huss and C. Schwinn, *Mixed QCD-electroweak $\mathcal{O}(\alpha_s\alpha)$ corrections to Drell-Yan processes in the resonance region: pole approximation and non-factorizable corrections*, Nucl. Phys. B **885**, 318 (2014), doi:[10.1016/j.nuclphysb.2014.05.027](https://doi.org/10.1016/j.nuclphysb.2014.05.027).
- [5] S. Dittmaier, A. Huss and C. Schwinn, *Dominant mixed QCD-electroweak $\mathcal{O}(\alpha_s\alpha)$ corrections to Drell-Yan processes in the resonance region*, Nucl. Phys. B **904**, 216 (2016), doi:[10.1016/j.nuclphysb.2016.01.006](https://doi.org/10.1016/j.nuclphysb.2016.01.006).
- [6] C. M. Carloni Calame, M. Chiesa, H. Martinez, G. Montagna, O. Nicrosini, F. Piccinini and A. Vicini, *Precision measurement of the W-boson mass: Theoretical contributions and uncertainties*, Phys. Rev. D **96**, 093005 (2017), doi:[10.1103/PhysRevD.96.093005](https://doi.org/10.1103/PhysRevD.96.093005).
- [7] D. de Florian, M. Der and I. Fabre, *QCD \oplus QED NNLO corrections to Drell-Yan production*, Phys. Rev. D **98**, 094008 (2018), doi:[10.1103/PhysRevD.98.094008](https://doi.org/10.1103/PhysRevD.98.094008).
- [8] L. Cieri, D. de Florian, M. Der and J. Mazzitelli, *Mixed QCD \otimes QED corrections to exclusive Drell Yan production using the q_T -subtraction method*, J. High Energy Phys. **09**, 155 (2020), doi:[10.1007/JHEP09\(2020\)155](https://doi.org/10.1007/JHEP09(2020)155).
- [9] R. Bonciani, F. Buccioni, N. Rana, I. Triscari and A. Vicini, *NNLO QCD \times EW corrections to Z production in the $q\bar{q}$ channel*, Phys. Rev. D **101**, 031301 (2020), doi:[10.1103/PhysRevD.101.031301](https://doi.org/10.1103/PhysRevD.101.031301).
- [10] R. Bonciani, F. Buccioni, N. Rana and A. Vicini, *Next-to-Next-to-Leading Order Mixed QCD-Electroweak Corrections to on-Shell Z Production*, Phys. Rev. Lett. **125**, 232004 (2020), doi:[10.1103/PhysRevLett.125.232004](https://doi.org/10.1103/PhysRevLett.125.232004).
- [11] S. Dittmaier, T. Schmidt and J. Schwarz, *Mixed NNLO QCD \times electroweak corrections of $\mathcal{O}(N_f\alpha_s\alpha)$ to single-W/Z production at the LHC*, J. High Energy Phys. **12**, 201 (2020), doi:[10.1007/JHEP12\(2020\)201](https://doi.org/10.1007/JHEP12(2020)201).
- [12] M. Heller, A. von Manteuffel, R. M. Schabinger and H. Spiesberger, *Mixed EW-QCD two-loop amplitudes for $q\bar{q} \rightarrow \ell^+\ell^-$ and γ_5 scheme independence of multi-loop corrections*, J. High Energy Phys. **05**, 213 (2021), doi:[10.1007/JHEP05\(2021\)213](https://doi.org/10.1007/JHEP05(2021)213).

- [13] L. Buonocore, M. Grazzini, S. Kallweit, C. Savoini and F. Tramontano, *Mixed QCD-electroweak corrections to $pp \rightarrow \ell \nu_\ell + X$ at the LHC*, Phys. Rev. D **103**, 114012 (2021), doi:[10.1103/PhysRevD.103.114012](https://doi.org/10.1103/PhysRevD.103.114012).
- [14] R. Bonciani, L. Buonocore, M. Grazzini, S. Kallweit, N. Rana, F. Tramontano and A. Vicini, *Mixed Strong-Electroweak Corrections to the Drell-Yan Process*, Phys. Rev. Lett. **128**, 012002 (2022), doi:[10.1103/PhysRevLett.128.012002](https://doi.org/10.1103/PhysRevLett.128.012002).
- [15] R. Bonciani, F. Buccioni, N. Rana and A. Vicini, *On-shell Z boson production at hadron colliders through $\mathcal{O}(\alpha_s)$* , J. High Energy Phys. **02**, 095 (2022), doi:[10.1007/JHEP02\(2022\)095](https://doi.org/10.1007/JHEP02(2022)095).
- [16] M. Delto, M. Jaquier, K. Melnikov and R. Röntsch, *Mixed QCD \otimes QED corrections to on-shell Z boson production at the LHC*, J. High Energy Phys. **01**, 043 (2020), doi:[10.1007/JHEP01\(2020\)043](https://doi.org/10.1007/JHEP01(2020)043).
- [17] F. Buccioni, F. Caola, M. Delto, M. Jaquier, K. Melnikov and R. Röntsch, *Mixed QCD-electroweak corrections to on-shell Z production at the LHC*, Phys. Lett. B **811**, 135969 (2020), doi:[10.1016/j.physletb.2020.135969](https://doi.org/10.1016/j.physletb.2020.135969).
- [18] A. Behring, F. Buccioni, F. Caola, M. Delto, M. Jaquier, K. Melnikov and R. Röntsch, *Mixed QCD-electroweak corrections to W-boson production in hadron collisions*, Phys. Rev. D **103**, 013008 (2021), doi:[10.1103/PhysRevD.103.013008](https://doi.org/10.1103/PhysRevD.103.013008).
- [19] A. Behring, F. Buccioni, F. Caola, M. Delto, M. Jaquier, K. Melnikov and R. Röntsch, *Estimating the impact of mixed QCD-electroweak corrections on the W-mass determination at the LHC*, Phys. Rev. D **103**, 113002 (2021), doi:[10.1103/PhysRevD.103.113002](https://doi.org/10.1103/PhysRevD.103.113002).
- [20] R. Bonciani, S. Di Vita, P. Mastrolia and U. Schubert, *Two-loop master integrals for the mixed EW-QCD virtual corrections to Drell-Yan scattering*, J. High Energy Phys. **09**, 091 (2016), doi:[10.1007/JHEP09\(2016\)091](https://doi.org/10.1007/JHEP09(2016)091).
- [21] A. von Manteuffel and R. M. Schabinger, *Numerical multi-loop calculations via finite integrals and one-mass EW-QCD Drell-Yan master integrals*, J. High Energy Phys. **04**, 129 (2017), doi:[10.1007/JHEP04\(2017\)129](https://doi.org/10.1007/JHEP04(2017)129).
- [22] M. Heller, A. von Manteuffel and R. M. Schabinger, *Multiple polylogarithms with algebraic arguments and the two-loop EW-QCD Drell-Yan master integrals*, Phys. Rev. D **102**, 016025 (2020), doi:[10.1103/PhysRevD.102.016025](https://doi.org/10.1103/PhysRevD.102.016025).
- [23] S. M. Hasan and U. Schubert, *Master integrals for the mixed QCD-QED corrections to the Drell-Yan production of a massive lepton pair*, J. High Energy Phys. **11**, 107 (2020), doi:[10.1007/JHEP11\(2020\)107](https://doi.org/10.1007/JHEP11(2020)107).
- [24] A. Kotikov, J. H. Kühn and O. Veretin, *Two-loop formfactors in theories with mass gap and Z-boson production*, Nucl. Phys. B **788**, 47 (2008), doi:[10.1016/j.nuclphysb.2007.07.018](https://doi.org/10.1016/j.nuclphysb.2007.07.018).
- [25] U. Aglietti and R. Bonciani, *Master integrals with one massive propagator for the two-loop electroweak form factor*, Nucl. Phys. B **668**, 3 (2003), doi:[10.1016/j.nuclphysb.2003.07.004](https://doi.org/10.1016/j.nuclphysb.2003.07.004).
- [26] U. Aglietti and R. Bonciani, *Master integrals with 2 and 3 massive propagators for the 2-loop electroweak form factor-planar case*, Nucl. Phys. B **698**, 277 (2004), doi:[10.1016/j.nuclphysb.2004.07.018](https://doi.org/10.1016/j.nuclphysb.2004.07.018).

- [27] F. Caola, K. Melnikov and R. Röntsch, *Nested soft-collinear subtractions in NNLO QCD computations*, Eur. Phys. J. C **77**, 248 (2017), doi:[10.1140/epjc/s10052-017-4774-0](https://doi.org/10.1140/epjc/s10052-017-4774-0).
- [28] F. Caola, K. Melnikov and R. Röntsch, *Analytic results for color-singlet production at NNLO QCD with the nested soft-collinear subtraction scheme*, Eur. Phys. J. C **79**, 386 (2019), doi:[10.1140/epjc/s10052-019-6880-7](https://doi.org/10.1140/epjc/s10052-019-6880-7).
- [29] F. Caola, K. Melnikov and R. Röntsch, *Analytic results for decays of color singlets to gg and $q\bar{q}$ final states at NNLO QCD with the nested soft-collinear subtraction scheme*, Eur. Phys. J. C **79**, 1013 (2019), doi:[10.1140/epjc/s10052-019-7505-x](https://doi.org/10.1140/epjc/s10052-019-7505-x).
- [30] K. Asteriadis, F. Caola, K. Melnikov and R. Röntsch, *Analytic results for deep-inelastic scattering at NNLO QCD with the nested soft-collinear subtraction scheme*, Eur. Phys. J. C **80**, 8 (2020), doi:[10.1140/epjc/s10052-019-7567-9](https://doi.org/10.1140/epjc/s10052-019-7567-9).