

# The $\pi^0$ mass and the first experimental verification of Coulomb de-excitation in pionic hydrogen

M. Daum<sup>1\*</sup> and P.-R. Kettle<sup>1</sup>

<sup>1</sup> Paul Scherrer Institut, 5232 Villigen PSI, Switzerland  
\* manfred.daum@psi.ch

April 19, 2021



Review of Particle Physics at PSI  
doi:[10.21468/SciPostPhysProc.2](https://doi.org/10.21468/SciPostPhysProc.2)

## Abstract

The most precise value for the  $\pi^0$  mass was obtained from the measurement of the mass difference  $m_{\pi^-} - m_{\pi^0} = 4.593\,64(48)\text{ MeV}/c^2$  in the charge exchange reaction  $\pi^- p \rightarrow \pi^0 n$  at PSI. With the most precise charged pion mass value,  $m_{\pi^+} = 139.570\,21(14)\text{ MeV}/c^2$  and the validity of the CPT theorem ( $m_{\pi^-} = m_{\pi^+}$ ), a value  $m_{\pi^0} = 134.976\,57(50)\text{ MeV}/c^2$  is obtained. The measurements also revealed, for the first time, evidence of an unexpectedly large contribution from Coulomb de-excitation states during the pionic atom cascade.

## 12.1 The mass of the $\pi^0$

A motivation in 1984 for a precision measurement of  $m_{\pi^0}$  was that it allowed for a far more precise comparison of experiment and theory for the rare pion  $\beta$  decay rate  $\Gamma_{\pi\beta}(\pi^+ \rightarrow \pi^0 e^+ \nu)$ , for which the phase space depends on the fifth-power of  $D_\pi = m_{\pi^-} - m_{\pi^0}$ . This required a precision on  $D_\pi$  to better than  $\Delta D_\pi/D_\pi < 0.001$ , a condition that was not met by the world average at the time [1–3].

In this measurement of  $D_\pi$ , negative pions are stopped in a liquid-hydrogen target to form pionic hydrogen atoms. A fraction  $R \approx R_p/(R_p + 1) \approx 0.6$  of these  $\pi^- p$  atoms, where  $R_p$  is the Panofsky ratio [4], undergo the charge-exchange reaction (CEX)



whereas the remaining 40 % of the  $\pi^- p$  atoms undergo radiative capture



The mass difference  $D_\pi$  is derived from time-of-flight (TOF) distributions of neutrons from reaction (12.1), measured at flight distances of 3.2, 7.9, and 18.1 m. Since the  $\pi^- p$  atoms are almost at rest, these neutrons generate a TOF peak corresponding to their velocity of about 0.894 cm/ns.

If the  $\pi^- p$  atom is at rest before reaction (12.1), energy and momentum conservation lead to the following equation for the mass difference  $D_\pi$ :

$$D_\pi = m_{\pi^-} - [(m_{\pi^-} - D_N - E_B)^2 - 2(\gamma_{nr} - 1)(m_p + D_N)(m_{\pi^-} + m_p - E_B)]^{1/2}. \quad (12.3)$$

Here,  $D_N \equiv m_n - m_p$  is the nucleon mass difference and  $E_B$  is the binding energy of the  $\pi^- p$  atom just prior to reaction (12.1). The rest mass of the  $\pi^- p$  atom is  $m_{\pi p} = m_{\pi^-} + m_p - E_B$ ;

## 12.1 The mass of the $\pi^0$

34  $\gamma_{nr} \equiv (1 + \beta_{nr}^2)^{-1/2}$  is the usual function of the neutron velocity  $v_{nr} = c\beta_{nr}$  for  $\pi^- p$  atoms at  
 35 rest; we set  $c = 1$ , except where the units are given explicitly.

36 From (12.3) it follows that the experimental uncertainty of  $D_\pi$  contains five contributions,  
 37  $\beta_{nr}$ ,  $m_{\pi^-}$ ,  $m_p$ ,  $D_N$ , and  $E_B$ , see [5–7], resulting in a relative uncertainty of  $D_\pi$  of the same order  
 38 as that of  $\beta_{nr}$ :

$$(\Delta D_\pi)_{\beta_{nr}}/D_\pi = 1.46\Delta\beta_{nr}/\beta_{nr}. \quad (12.4)$$

39 The remaining four contributions can be neglected, see [7]. Thus, the experiment consists of  
 40 determining the velocity of the neutron from the charge-exchange reaction (12.1).

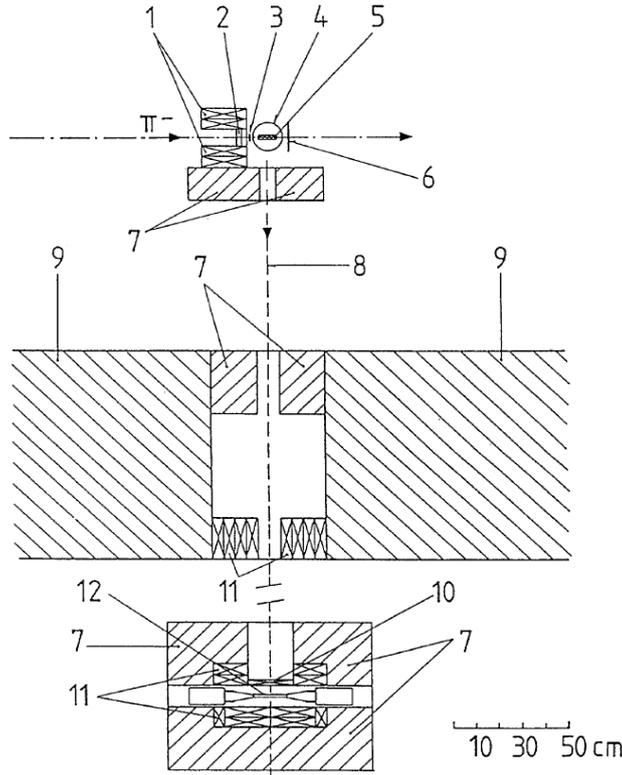

Figure 12.1: Experimental setup: (1) lead collimator; (2)  $\text{CH}_2$  degrader; (3) Scintillator  $S_1$ ; (4) vacuum chamber of the liquid hydrogen target; (5) liquid hydrogen target; (6) scintillator  $S_2$ ; (7)  $\text{CH}_2$  shielding; (8) central neutron trajectory; (9) concrete shielding; (10) lead converter; (11) lead collimator; (12) Scintillator  $S_3$ .

41 The measurements were made at the 590 MeV proton accelerator at PSI. The experimen-  
 42 tal layout is shown in Figure 12.1. Negative pions with a momentum of 120 MeV/c were  
 43 transported by the secondary beam line  $\pi E1$  to a liquid hydrogen target assembly. At that  
 44 momentum, the substantial electron contamination in the beam was suppressed using time-  
 45 of-flight (TOF), by requiring a coincidence between the scintillator  $S_1$  and the radio frequency  
 46 signal of the accelerator.

47 The pions passed through a  $\text{CH}_2$  degrader, optimized to maximize the pion stopping rate  
 48 in the liquid hydrogen. The hydrogen was contained in a cylindrical stainless steel cell with a  
 49 length of 1.6 cm and a radius of 4.5 cm, oriented so that the cylinder axis coincided with the  
 50 neutron flight direction, see Figure 12.1.

51 The incoming pions were detected by a plastic scintillator  $S_1$  in anti-coincidence with the  
 52 scintillator  $S_2$ . The coincidence  $(S_1 \cdot \text{rf}) \cdot (S_2 \cdot \text{rf})$  indicated a stopping pion. Neutrons and pho-

53 tons from the liquid hydrogen target were observed after a flight path of variable length (3-18  
54 m) defined by a series of  $\text{CH}_2$  and Pb collimators.

55 The neutrons and photons from reactions (12.1) and (12.2) were detected by a NE102A  
56 organic scintillator  $S_3$  of thickness 1.6 cm viewed from opposite sides through lucite light  
57 guides by two photomultipliers. The neutron detector was shielded by  $\text{CH}_2$  and lead as shown  
58 in Figure 12.1. The neutron detector assembly was mounted on a steel cart equipped with  
59 optical targets for surveying.

60 Data were taken with the neutron detector at three distances from the nominal hydrogen  
61 target location: (i) 3.1966 m, (ii) 7.9283 m, and (iii) 18.1005 m. The distance between  
62 positions (i) and (ii) was determined to  $\pm 0.1$  mm and that between positions (i) and (iii) to  
63  $\pm 0.4$  mm. For more information see [7].

64 The method of determining the neutron velocity is similar to that of [1]. However, the  
65 older method depended on the measurement of signal velocities in the coaxial delay cables,  
66 whereas in our case this time standard is replaced by the precisely known radio frequency  
67 structure of the pion beam. The neutron velocity  $v_{nr}$  from the charge exchange reaction (12.1)  
68 is derived from the position of the neutron peak in the TOF spectra (Figure 12.2) relative  
69 to the pattern of the accidental photon peaks. These peaks appear at regular intervals of  
70  $\tau_{rf} = (19.750\,034 \pm 0.000\,002)$  ns.

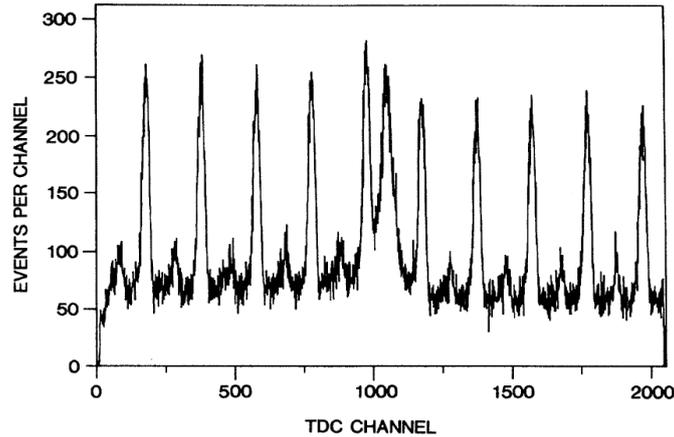

Figure 12.2: Uncorrected time spectrum recorded at a flight path of  $l = 7.9$  m. Abscissa: TDC channel number for  $S_3$ ; channel  $\approx 0.1$  ns. Ordinate: number of events per channel. This distribution contains three classes of events: (a) The peak at channel 1040 of Figure 12.2 is due to neutrons from the charge exchange reaction (12.1). (b) The narrow peaks at channels 180, 380, 580, ..., are due to photons from the  $\pi^0$  decay following reaction (12.1) and photons from reaction (12.2). (c) The small peaks about halfway between the photon peaks, i.e., at channels 80, 280, 480, ..., originate from accidental events in which the TDC was started by a neutron detector signal due to beam electrons scattered in the liquid hydrogen target assembly.

71 The raw time distribution of the events, as recorded by a time-to-digital converter (TDC)  
72 at a flight path of 7.9 m, is shown in Figure 12.2. The data are shown in Figure 12.3 after  
73 background subtraction, for all three distances.

74 Neglecting the fact that the  $\pi^- p$  atoms have a finite kinetic energy  $T_{\pi p}$  and are in different  
75 atomic states at the time of reaction (12.1), all neutrons from that reaction would have the  
76 same velocity,  $v_{nr}$ , which is related to the particle masses by energy and momentum conserva-

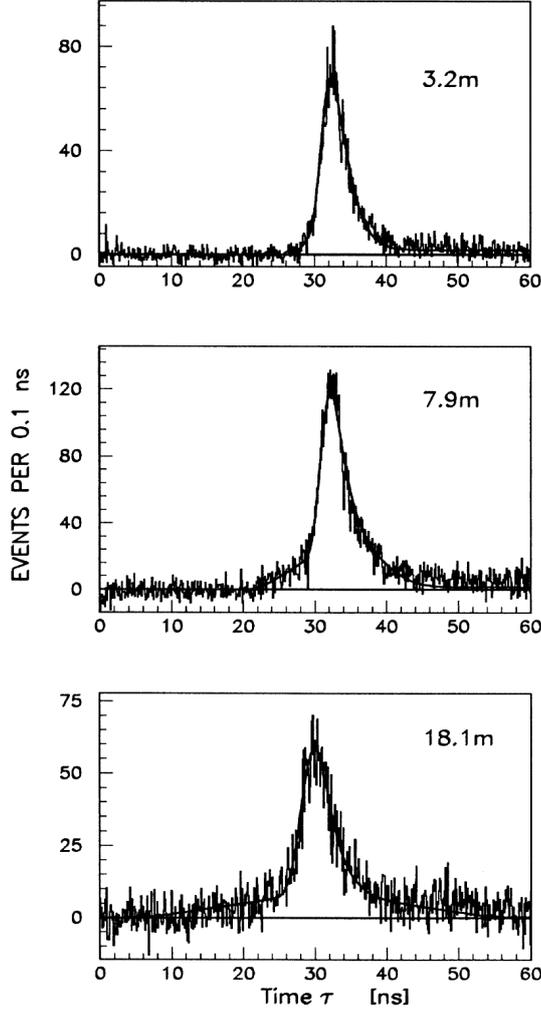

Figure 12.3: Experimental TOF spectra of neutrons from the charge exchange reaction  $\pi^- p \rightarrow \pi^0 n$ , after background subtraction, for flight paths of 3.2 m, 7.9 m, and 18.1 m. The time shown is from an accidental photon peak about 30 ns before the neutron peak. Curves: theoretical distributions fitted to the data, c.f. [7].

77 tion ( $c = 1$ )

$$m_{\pi p} = E_n + E_{\pi^0} = \sqrt{m_n^2 + p_n^2} + \sqrt{m_{\pi^0}^2 + p_{\pi^0}^2}. \quad (12.5)$$

78 Here,  $E_n$  and  $E_{\pi^0}$  are the total neutron and  $\pi^0$  energies, respectively, and  $p_n = m_n \beta_{nr} \gamma$  is the  
79 neutron momentum.

80 Without the assumption of the initial  $\pi^- p$  atoms being at rest, the predicted neutron TOF  
81 distribution  $F(\tau)$  for a given neutron flight path  $l_n$  has a finite width. It can be shown [7]  
82 that, for an isotropic distribution of the  $\pi^- p$  atom velocities, the mean of the neutron TOF  
83 distribution is equal to the TOF for  $\pi^- p$  atoms at rest. The standard deviation of the function  
84  $F(\tau)$  is [7]

$$\sigma_\tau = (2\overline{T_{\pi p}}/3m_{\pi p})^{1/2} l_n / v_{nr}^2, \quad (12.6)$$

85 where  $\overline{T_{\pi p}}$  is the mean kinetic energy of the  $\pi^- p$  atom. It is seen from (12.6) that the standard  
86 deviation of the TOF distribution function  $F(\tau)$  increases linearly with the neutron flight path  
87  $l_n$ .

88 The broadening of the TOF peaks with increasing flight path is indeed observed in the  
 89 spectra of Figure 12.3. The tails to the right of the neutron peaks, i.e., to longer times-of-flight,  
 90 are due not only to the finite kinetic energy of the  $\pi^-p$  atoms but also to neutrons which have  
 91 reached the detector after scattering in the materials in and around the flight channel. In  
 92 contrast, the tails to the left are not contaminated by neutron scattering. The tail visible at  
 93 3.2 m, extends to about 10 ns (20 ns) before the peak at 7.9 m (18.1 m), corresponding to an  
 94 energy distribution  $f(T_{\pi p})$  extending to about 70 eV.

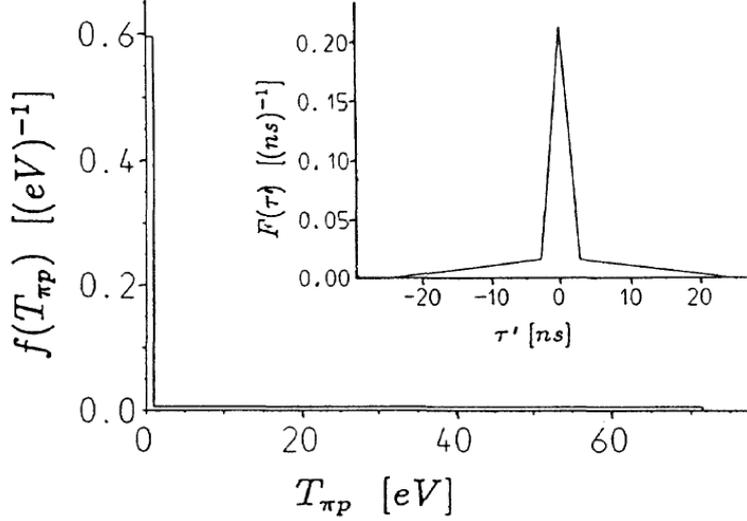

Figure 12.4: Model distribution function  $f(T_{\pi p})$  found to fit the neutron TOF spectra of Figure 12.3;  $T_{\pi p}$  is the kinetic energy of the  $\pi^-p$  atom just prior to the charge exchange reaction (12.1);  $F(\tau')$  is the corresponding neutron TOF distribution for a flight path of 18.1 m.

95 The curves in Figure 12.3 were obtained by fitting nine free parameters simultaneously to  
 96 all three experimental spectra, for details see [7]. An energy distribution found to fit the data  
 97 is shown in Figure 12.4 together with the corresponding neutron TOF distribution  $F(\tau)$  for a  
 98 fixed flight path of 18.1 m. The  $\chi^2$  of the fit shown in Figure 12.3 is 1265 for 1191 degrees of  
 99 freedom.

100 The resulting neutron velocity from the charge exchange reaction (12.1) and for the  $\pi^-p$   
 101 atom at rest is

$$v_{nr} = (0.894\,266 \pm 0.000\,063) \text{ cm/ns.} \quad (12.7)$$

102 The corresponding mass difference is

$$D_\pi = m_{\pi^-} - m_{\pi^0} = (4.593\,64 \pm 0.000\,48) \text{ MeV}/c^2. \quad (12.8)$$

103 This result agrees with our previous measurement [5]. The deviation from the former world av-  
 104 erage [3], ( $D_\pi = 4.604\,3 \pm 0.003\,7$ ) MeV/ $c^2$ , which was dominated by the values of [1,2] is thus  
 105 confirmed at a level of  $2.9\sigma$ . Assuming the validity of the CPT theorem ( $m_{\pi^+} = m_{\pi^-}$ ), subtract-  
 106 ing the mass difference (12.8) from the charged pion mass [8],  $m_{\pi^+} = 139.570\,21(14)$  MeV/ $c^2$   
 107 gives the new  $\pi^0$  mass value,

$$m_{\pi^0} = (134.976\,57 \pm 0.000\,50) \text{ MeV}/c^2. \quad (12.9)$$

108 A similar analysis based on the fast neutron TOF spectra from the simultaneously measured  
 109 radiative capture reaction (12.2) results in a value for the negative pion mass, consistent with

110 the world average value, albeit with reduced precision. As the dominant uncertainty is from  
 111 the neutron velocity, this provides evidence of the validity of the velocity analysis method used.

112 The fit also allows the extraction of the corresponding mean kinetic energy of the  $\pi^-p$   
 113 atom

$$\overline{T_{\pi p}} = (16.2 \pm 1.3) \text{ eV} \quad (12.10)$$

114 confirming the strong deviation from the velocity spread quoted in [1] which corresponded to  
 115  $\overline{T_{\pi p}} = (115 \pm 43) \text{ eV}$ .

## 116 12.2 First experimental verification of Coulomb de-excitation in pionic hydro- 117 gen

118 The TOF-data for the  $D_\pi$  measurement show a Doppler broadening of the neutron peaks with  
 119 increasing flight distance, attributed to 'high-energy' pionic atoms at the time of the CEX-  
 120 reaction. Further evidence for this was reported later by an experiment in gaseous hydrogen  
 121 [9].

122 The kinetic energy distribution  $f(T_{\pi p})$  and the corresponding TOF-distribution  $F(\tau)$  for  
 123 this simple model for the  $D_\pi$ -data was further refined in a new experiment, undertaken to prove  
 124 the existence of the Coulomb de-excitation process [10, 11] in liquid and gaseous hydrogen,  
 125 and to determine if it is responsible for the broadening. A further aim was to verify that the  
 126 multi-component structure of the kinetic energy distribution is associated with this process.

127 The motivation for this experiment was to test the cross-section predictions for various cas-  
 128 cade processes for exotic hydrogen atoms, which are important for experiments such as pionic  
 129 X-ray transition measurements to determine the ground state strong interaction width [12–14]  
 130 and the effect of the Doppler broadening of pionic X-ray lines in the determination of the pion-  
 131 nucleon scattering lengths. The most likely process capable of producing such a broadening  
 132 effect is Coulomb de-excitation [10, 11]. Here,  $(\pi^-p)_n + p \rightarrow (\pi^-p)_{n'} + p$  where the smaller  
 133 neutral pionic atom collides with a proton of a hydrogen atom causing a transition of the pi-  
 134 onic atom, whereby the de-excitation energy is shared between the collision partners. Other  
 135 possible processes either reduce  $T_{\pi p}$  or leave it almost unchanged. Coulomb de-excitation pre-  
 136 dictions calculated by several authors [11, 15–17] vary by more than an order-of-magnitude  
 137 so that precise data are necessary to test the predictions.

138 Here we outline the new experiment, concentrating on the liquid hydrogen results [18].  
 139 Several experimental improvements [5–7] were implemented:

- 140 1. Background reduction and increased statistics by use of (i) an extra neutron collimator  
 141 system close to the target, (ii) an array of neutron counters with specially selected low-  
 142 noise photomultipliers, and (iii) a 64-counter array of NaI photon counters for tagging  
 143 the neutrons from reactions (12.1) and (12.2).
- 144 2. Improved time-resolution, by reducing both the thickness of the neutron detectors and  
 145 the liquid hydrogen cell [18, 19].

146 In this experiment, negative pions of 117 MeV/c were slowed down in a carbon degrader  
 147 and stopped in a liquid hydrogen target. Neutrons from reaction (12.1) were detected for  
 148 various flight-path lengths between 3 and 11 m. Time-of-flight and pulse-height data were  
 149 recorded by time-to-digital (TDC) and analogue-to-digital (ADC) convertors.

150 Figure 12.5 shows the neutron TOF-spectra taken at 3.82 m, 8.39 m and 11.11 m, after  
 151 background subtraction and pulse-height cuts to remove noise and accidental photon events  
 152 from  $\pi^0$ -decay and radiative capture, as well as bremsstrahlung events from beam electrons.  
 153 Further energy cuts (between 60 and 110 MeV) on the photon detected in the NaI array elim-  
 154 inated both bremsstrahlung and radiative capture events. Figure 12.5 shows a clear distance-

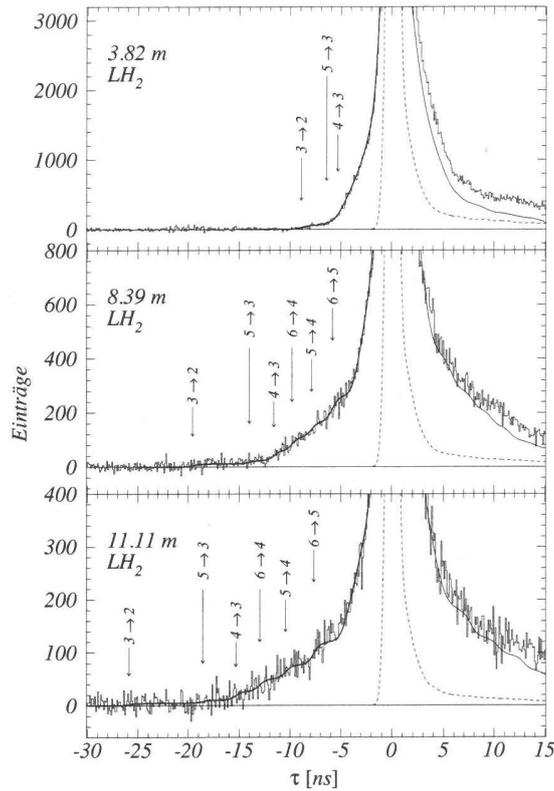

Figure 12.5: Neutron time-of-flight spectra from the charge exchange reaction  $\pi^-p \rightarrow \pi^0n$  in a liquid hydrogen target ( $\text{LH}_2$ ). The time is measured from the centre of the neutron peak corresponding to the reaction at rest. Solid curves: fit to the data including Coulomb de-excitation processes. The numbers  $n \rightarrow n'$  indicate the expected positions of the steps in the TOF distribution of neutrons emitted after the corresponding Coulomb de-excitation. Dashed line: unbroadened neutron TOF distribution from Monte Carlo program.

155 dependent broadening of the neutron line shape, when compared to the Mont-Carlo generated  
 156 intrinsic line shape.

157 The data of Figure 12.5 were analyzed by applying three fitting procedures; two based on  
 158 the full model of Coulomb de-excitation shown in Figure 12.6 - one including both  $\Delta n = 1$   
 159 and  $\Delta n = 2$  pionic atom transitions in the fitted  $F(\tau)$  distributions and one including only  
 160 the  $\Delta n = 1$  transitions. The third procedure used the simplified model of Figure 12.4 for  
 161 comparison.

162 Clear step-like structures in the data at 3.8 m and 8.4 m can be seen reaching to  $-9$  ns and  
 163  $-20$  ns, respectively, corresponding to the  $\Delta n = 1$  transition  $3 \rightarrow 2$  having a kinetic energy of  
 164 209 eV. A second component visible at all three distances corresponding to  $-6$  ns,  $-12$  ns and  
 165  $-15$  ns, signals the  $\Delta n = 1$  transition  $4 \rightarrow 3$  in the pionic atom with a kinetic energy of about  
 166 70 eV.

167 The final results from the experiment for the kinetic energy distribution for pionic hydro-  
 168 gen, based on Coulomb de-excitation transitions, are shown in Table 12.1, for both liquid and  
 169 gaseous hydrogen and are based on the three independent fits [18]. Although visually, the  
 170 significance of the steps in the TOF-spectra is only fair, their true significance can be seen from  
 171 the fit results in the table, when the theoretical model of Figure 12.6 is fitted simultaneously  
 172 to all three TOF spectra. Here, a 16-parameter fit of the model-based TOF spectra are fitted to

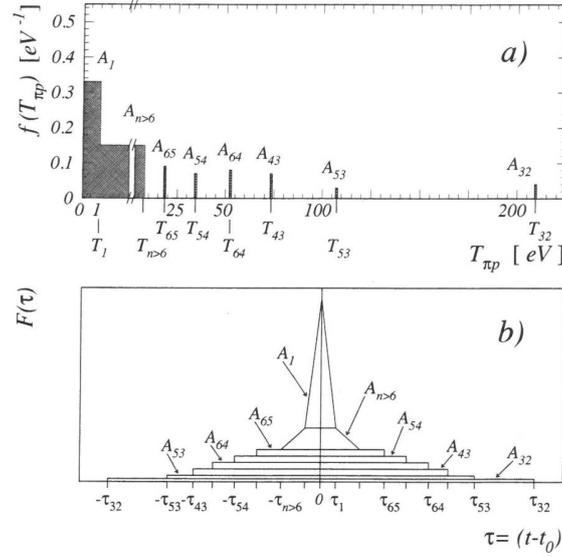

Figure 12.6: (a) Idealized distribution function  $f(T_{\pi p})$  of the kinetic energy  $T_{\pi p}$  of pionic hydrogen atoms at the instant of nuclear capture. For clarity,  $T_1$  and the widths of the four  $\delta$ -like peaks at  $T_{nn'}$  are drawn to be 1 eV. The energy distribution  $f(T_{n>6})$  is about 7 eV wide and describes all transitions  $n \rightarrow n'$  with  $n > 6$ . The integrals of these distributions and peaks correspond to the relative yields  $A_1$ ,  $A_{nn'}$  and  $A_{n>6}$ , respectively. (b) Neutron TOF-distribution  $F(\tau)$  corresponding to the kinetic energy distribution of Fig. 1(a).

173 the measured distributions and involve: (i) four yields from  $\Delta n = 1$  transition  $6 \rightarrow 5$ ,  $5 \rightarrow 4$ ,  
 174  $4 \rightarrow 3$  and  $3 \rightarrow 2$ ; (ii) two yields for  $\Delta n = 2$  transitions  $6 \rightarrow 4$  and  $5 \rightarrow 3$ ; (iii) one yield  
 175 and one upper energy bound for  $n > 6$  transitions; (iv) the energy parameter  $T_1$  for the low-  
 176 energy component; (v) a distance independent Gaussian electronic time-jitter [7]; (vi) three  
 177 normalization factors for the ordinates; (vii) three time shifts ( $0.3 \pm 0.1$ ) channels, as free  
 178 parameters.

179 The fits incorporating the  $\Delta n = 1$  and  $\Delta n = 2$  transitions gave a  $\chi^2/\text{DOF}$  of 0.96 with  
 180 740 degrees of freedom (DOF); this corresponds to a confidence level of 77.7%. The data  
 181 were also fit with the parameterization of [7] (two uniform kinetic-energy distributions of the  
 182  $\pi^-p$ -atom, cf. Figure 12.4). In this case, the resulting  $\chi^2$  was 2.43/DOF (cf. also [19]). The  
 183 poor fit due to this parameterization originates from the lack of discrete components, e.g. the  
 184  $3 \rightarrow 2$  transition.

185 For comparison, fits were also made excluding the Coulomb de-excitation components with  
 186  $\Delta n = 2$ . These fits gave a  $\chi^2/\text{DOF}$  of 1.06 with 742 DOF which corresponds to a confidence  
 187 level of 13.1%. The differences in the  $\chi^2/\text{DOF}$  between the fits with and without  $\Delta n = 2$   
 188 transitions are not very significant; however, there is strong evidence for components with  
 189  $\Delta n = 2$  from the two other model-independent methods used in the analysis to extract the  
 190 kinetic energy distribution  $f(T_{\pi p})$  from the data, see [18]. In addition, the difference between  
 191 the predicted and the observed transition energies  $T_{nn'}$  reported in [19] can be accounted for  
 192 and made to vanish in our present analysis if we include the  $\Delta n = 2$  Coulomb de-excitation  
 193 transitions. Then, the resultant energies  $T_{nn'}$  for  $n \leq 6$  perfectly match the theoretical values  
 194 derived from the Coulomb de-excitation model and do not have to be taken as free parameters.  
 195 This is considered as a strong indication of the existence of the  $\Delta n = 2$  Coulomb de-excitation  
 196 transitions.

transition	energy $T_{nn'}$ [eV]	$A_{nn'}$ [%]			
		LH <sub>2</sub>	H <sub>2</sub> gas	LH <sub>2</sub>	H <sub>2</sub> gas
$n > 6$	< 18.4	$27 \pm 2$	$19 \pm 5$	$26 \pm 2$	$21 \pm 5$
$6 \rightarrow 5$	18.4	$9 \pm 1$	$9 \pm 3$	$7 \pm 1$	$6 \pm 3$
$5 \rightarrow 4$	33.9	$7 \pm 1$	$7 \pm 4$	$12 \pm 1$	$14 \pm 3$
$4 \rightarrow 3$	73.2	$7 \pm 1$	$5 \pm 3$	$14 \pm 1$	$10 \pm 2$
$3 \rightarrow 2$	209.1	$3 \pm 1$	$5 \pm 1$	$4 \pm 1$	$4 \pm 1$
$6 \rightarrow 4$	52.3	$8 \pm 1$	$9 \pm 4$	/	/
$5 \rightarrow 3$	107.1	$3 \pm 1$	$0_{-0}^{+2}$	/	/
$\chi^2/\text{DOF}$		0.96	0.96	1.06	0.96
$T_1$ [eV]		$1.0 \pm 0.1$	$1.6 \pm 0.2$	$1.0 \pm 0.1$	$1.5 \pm 0.3$
$A_1$ [%]		$36 \pm 2$	$46 \pm 6$	$36 \pm 2$	$45 \pm 6$
$T_{n>6}$ [eV]		$7.6 \pm 0.3$	$6.7 \pm 2.2$	$7.9 \pm 0.4$	$6.8 \pm 2.3$

Table 12.1: Fitted yields  $A_{nn'}$  of Coulomb de-excitation peaks in the kinetic energy distribution  $f(T_{\pi p})$  for the transitions  $n \rightarrow n'$  in liquid and gaseous hydrogen. Fit results including  $\Delta n = 2$  (left) and  $\Delta n = 1$  only (right).

## 197 References

- 198 [1] J. B. Czirr, *Determination of pi-Meson Masses by Neutron Time of Flight*, Phys. Rev. **130**,  
199 341 (1963), doi:[10.1103/PhysRev.130.341](https://doi.org/10.1103/PhysRev.130.341).
- 200 [2] I. M. Vasilevsky, V. V. Vishnyakov and A. F. Dunaitsev, *Mass Difference of the Negative and*  
201 *Neutral Pions*, Phys. Lett. **23**, 281 (1966), doi:[10.1016/0031-9163\(66\)90184-3](https://doi.org/10.1016/0031-9163(66)90184-3).
- 202 [3] M. Aguilar-Benitez *et al.*, *Review of Particle Properties. Particle Data Group*, Phys. Lett. B  
203 **170**, 1 (1986).
- 204 [4] W. K. H. Panofsky, R. L. Aamodt and J. Hadley, *The Gamma-Ray Spectrum Resulting from*  
205 *Capture of Negative pi-Mesons in Hydrogen and Deuterium*, Phys. Rev. **81**, 565 (1951),  
206 doi:[10.1103/PhysRev.81.565](https://doi.org/10.1103/PhysRev.81.565).
- 207 [5] J. F. Crawford, M. Daum, R. Frosch, B. Jost, P. R. Kettle, R. M. Marshall and K. O. H.  
208 Ziock, *Precision Measurement of the Mass Difference  $M(\pi^-) - M(\pi^0)$* , Phys. Rev. Lett. **56**,  
209 1043 (1986), doi:[10.1103/PhysRevLett.56.1043](https://doi.org/10.1103/PhysRevLett.56.1043).
- 210 [6] J. F. Crawford, M. Daum, R. Frosch, B. Jost, P. R. Kettle, R. M. Marshall, B. K. Wright and  
211 K. O. H. Ziock, *Precision Measurement of the Mass Difference  $M(\pi^-) - M(\pi^0)$* , Phys. Lett.  
212 B **213**, 391 (1988), doi:[10.1016/0370-2693\(88\)91782-0](https://doi.org/10.1016/0370-2693(88)91782-0).
- 213 [7] J. F. Crawford, M. Daum, R. Frosch, B. Jost, P. R. Kettle, R. M. Marshall, B. K. Wright and  
214 K. O. H. Ziock, *Precision measurement of the pion mass difference  $m(\pi^-) - m(\pi^0)$* , Phys.  
215 Rev. D **43**, 46 (1991), doi:[10.1103/PhysRevD.43.46](https://doi.org/10.1103/PhysRevD.43.46).
- 216 [8] M. Daum, R. Frosch and P. R. Kettle, *The charged and neutral pion masses revisited*, Phys.  
217 Lett. **B796**, 11 (2019), doi:[10.1016/j.physletb.2019.07.027](https://doi.org/10.1016/j.physletb.2019.07.027).
- 218 [9] E. C. Aschenauer *et al.*, *Cascade processes and the kinetic-energy distribution of pionic*  
219 *hydrogen atoms*, Phys. Rev. A **51**, 1965 (1995), doi:[10.1103/PhysRevA.51.1965](https://doi.org/10.1103/PhysRevA.51.1965).
- 220 [10] M. Leon and H. A. Bethe, *Negative Meson Absorption in Liquid Hydrogen*, Phys. Rev. **127**,  
221 636 (1962), doi:[10.1103/PhysRev.127.636](https://doi.org/10.1103/PhysRev.127.636).

- 222 [11] L. Bracci and G. Fiorentini, *Coulomb Deexcitation of Mesic Hydrogen*, Nuovo Cim. A **43**,  
223 9 (1978), doi:[10.1007/BF02729003](https://doi.org/10.1007/BF02729003).
- 224 [12] W. Beer *et al.*, *Determination of the strong interaction shift in pionic hydrogen with a high*  
225 *resolution crystal spectrometer system*, Phys. Lett. B **261**, 16 (1991), doi:[10.1016/0370-](https://doi.org/10.1016/0370-2693(91)91317-0)  
226 [2693\(91\)91317-0](https://doi.org/10.1016/0370-2693(91)91317-0).
- 227 [13] D. Sigg *et al.*, *The Strong interaction shift and width of the 1S level in pionic hydrogen*,  
228 Phys. Rev. Lett. **75**, 3245 (1995), doi:[10.1103/PhysRevLett.75.3245](https://doi.org/10.1103/PhysRevLett.75.3245).
- 229 [14] D. Sigg *et al.*, *The strong interaction shift and width of the ground state of pionic hydro-*  
230 *gen*, Nucl. Phys. A **609**, 269 (1996), doi:[10.1016/S0375-9474\(96\)00280-1](https://doi.org/10.1016/S0375-9474(96)00280-1), [Erratum:  
231 Nucl.Phys.A 617, 526–526 (1997)].
- 232 [15] L. Men'shikov, *Mesic Atom Acceleration Mechanisms in Cascade Transitions*, Muon Cat-  
233 alyzed Fusion **2**, 173 (1988).
- 234 [16] W. Czaplinski, A. Gula, A. Kravtsov, A. Mikhailov and N. Popov, *Kinetics of excited muonic*  
235 *hydrogen*, Phys. Rev. A **50**, 525 (1994), doi:[10.1103/PhysRevA.50.525](https://doi.org/10.1103/PhysRevA.50.525).
- 236 [17] L. I. Ponomarev and E. A. Solov'ev, *Cascade acceleration of p pi atoms in the Coulomb*  
237 *deexcitation process*, JETP Lett. **64**, 135 (1996), doi:[10.1134/1.567164](https://doi.org/10.1134/1.567164).
- 238 [18] A. Badertscher, P. F. A. Goudsmit, M. Janousch, Z. G. Zhao, M. Daum, P. R. Kettle, V. E.  
239 Markushin, J. Schottmueller and J. Koglin, *Experimental verification of Coulomb deexcita-*  
240 *tion in pionic hydrogen*, Europhys. Lett. **54**, 313 (2001), doi:[10.1209/epl/i2001-00243-](https://doi.org/10.1209/epl/i2001-00243-1)  
241 [1](https://doi.org/10.1209/epl/i2001-00243-1).
- 242 [19] A. Badertscher, M. Daum, R. Frosch, P. F. A. Goudsmit, W. Hajdas, M. Janousch, P. R.  
243 Kettle, V. Markushin, J. Schottmuller and Z. G. Zhao, *Experimental determination of the*  
244 *kinetic energy distribution of pi- p atoms in liquid hydrogen*, Phys. Lett. B **392**, 278 (1997),  
245 doi:[10.1016/S0370-2693\(96\)01545-6](https://doi.org/10.1016/S0370-2693(96)01545-6).