

# The DarkSide–20k TPC and Underground Argon Cryogenic System

T. N. Thorpe<sup>1</sup> on behalf of the DS–20k Collaboration,

<sup>1</sup> Department of Physics and Astronomy, University of California – Los Angeles, 475 Portola Plaza, Los Angeles, CA 90095  
tnthorpe@g.ucla.edu

October 1, 2022



*14th International Conference on Identification of Dark Matter*  
Vienna, Austria, 18-22 July 2022  
doi:[10.21468/SciPostPhysProc.7](https://doi.org/10.21468/SciPostPhysProc.7)

## Abstract

DarkSide–20k (DS–20k) will exploit the physical and chemical properties of liquid argon housed within a large dual-phase time projection chamber (TPC) in its direct search for dark matter. The TPC will utilize a compact, integrated design with many novel features to enable the 20 t fiducial volume of underground argon. Underground Argon (UAr) is sourced from underground CO<sub>2</sub> wells and depleted in the radioactive isotope <sup>39</sup>Ar, greatly enhancing the experimental sensitivity to dark matter interactions. Sourcing and transporting the  $\mathcal{O}(100\text{ t})$  of UAr for DS–20k is costly, and a dedicated single-closed-loop cryogenic system has been designed, constructed, and tested to handle the valuable UAr. We present an overview of the DS–20k TPC design and the first results from the UAr cryogenic system.

---

## Contents

<b>1</b>	<b>Introduction</b>	<b>2</b>
<b>2</b>	<b>Overview of the DarkSide–20k Time Projection Chamber (TPC)</b>	<b>2</b>
<b>3</b>	<b>The DarkSide–20k Underground Argon (UAr) Cryogenic System</b>	<b>3</b>
3.1	Design Overview	4
3.2	Preliminary Commissioning Results	5
3.2.1	Cooling Power Recovery Efficiency	5
3.2.2	Detector Circulation	6
<b>4</b>	<b>Conclusion</b>	<b>6</b>
<b>A</b>	<b>DS–20k UAr Cryogenic System P&amp;ID</b>	<b>8</b>
	<b>References</b>	<b>8</b>

---

## 1 Introduction

DarkSide–20k (DS–20k) is an upcoming direct dark matter search experiment and will be located in the underground laboratory of the Gran Sasso National Laboratory (LNGS) in Assergi, IT. DS–20k is designed to observe dark matter particles scattering from argon atoms in the liquid argon (LAr) target. The visible signal from Weakly Interacting Massive Particle (WIMP) dark matter scattering is a nuclear recoil, depositing energies up to  $\mathcal{O}(100)$  keV within the LAr. The detector is designed to operate for a minimum of 10 years while maintaining a negligible instrumental background level in the WIMP search region of interest.

The core of the DS–20k experiment is a dual–phase Time Projection Chamber (TPC) which will be filled and surrounded with low–radioactivity Underground Argon (UAr). The level of the  $\beta$ –emitting radioactive isotope,  $^{39}\text{Ar}$  in UAr is less ( $\approx 1400\times$ ) than that of standard argon of atmospheric origin (AAr), as demonstrated [1] by the predecessor experiment DarkSide–50. The fiducial volume of DS–20k is 20 t, which gives a minimum design exposure of 200 t  $\times$  years using UAr. We briefly overview the DS–20k TPC and UAr cryogenic system design, and discuss the first cryogenic testing results.

## 2 Overview of the DarkSide–20k Time Projection Chamber (TPC)

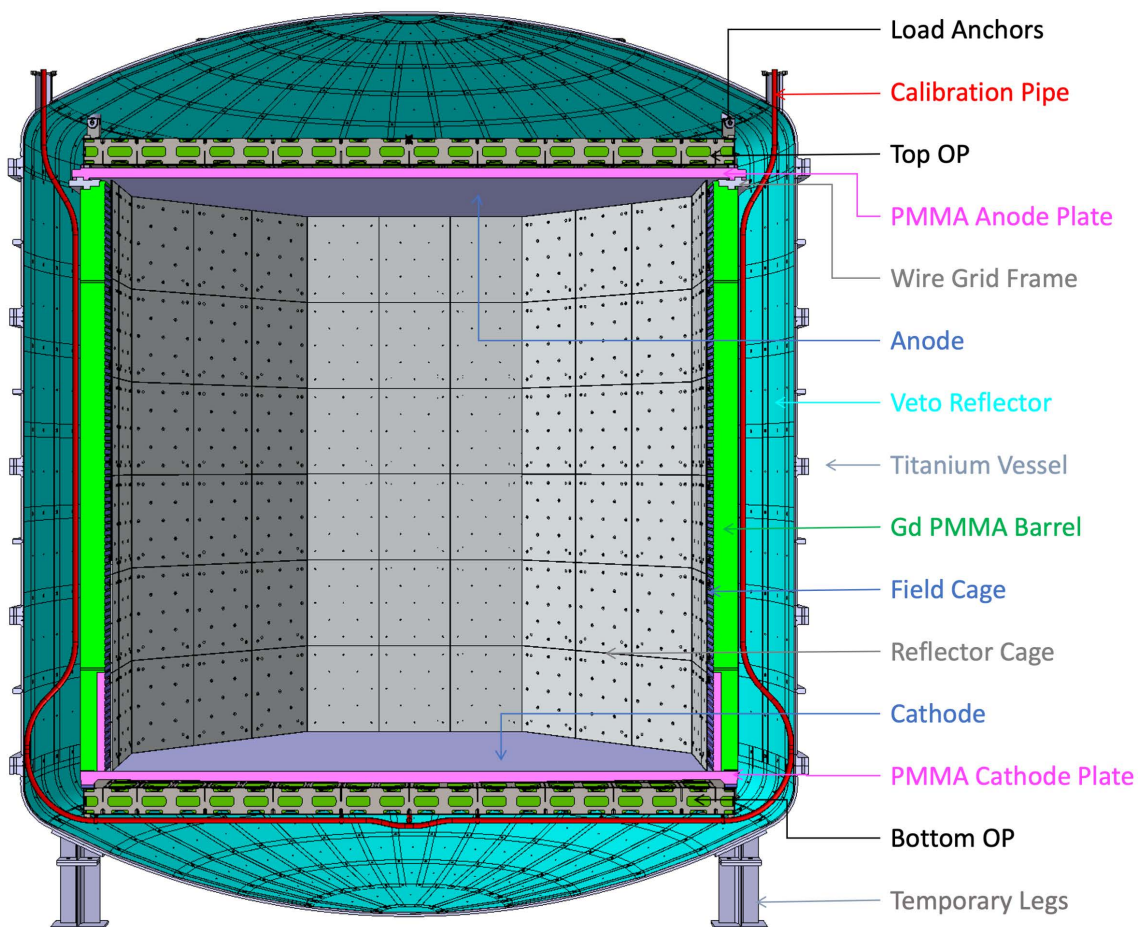

Figure 1: Cross–section view of the DS–20k TPC and neutron veto within the stainless steel vessel which will house the Underground Argon (UAr).

The DS–20k TPC and active neutron veto are two sides of the same mechanical object, which is pictured in Fig. 1. Eight gadolinium (Gd) loaded PMMA (acrylic) panels (green in Fig. 1) will be mounted together to form the *TPC barrel* with the Gd serving as a high cross section target for thermal neutrons. The panels measure  $365\text{ cm} \times 163\text{ cm}$  ( $l \times w$ ) and are 15 cm thick except for the bottom section that the cathode barrel fits into, where they measure 10 cm thick. The *anode* and *cathode* plates, as they’re labeled in Fig. 1, are pure PMMA pieces coated with Clevios<sup>TM</sup> and 1,1,4,4-tetraphenyl-1,3-butadiene (TPB). Clevios<sup>TM</sup> is a commercial conductive polymer and will be used to define most of the electrical potentials in the TPC. The TPB coating has a nominal application density of  $200\text{ }\mu\text{g}/\text{cm}^2$ , and is used to wavelength shift the 128 nm argon scintillation light to  $\approx 420\text{ nm}$  to be efficiently detected by the Silicon Photomultiplier (SiPM)–based readout. Mounted on the interior panel walls is the *reflector cage* composed of 4 mm thick PMMA panels combined with TPB–coated 50  $\mu\text{m}$  thick Enhanced Specular Reflector (ESR) foils.

The anode plate is 5 cm thick, has a small 13 mm “lip” to contain the gas pocket, and eight holes machined around the edge connecting to the UAr cryogenic system to control the flow into and out of the gas pocket region. The cathode plate has a sloping exterior surface, hence a varying thickness of 7 cm at the center to 5 cm at the edges, to avoid trapping any gas bubbles beneath. The cathode plate has a bonded barrel section which fits inside of the TPC barrel such that the inner surfaces containing the machined Clevios<sup>TM</sup> coated grooves (field cage rings) align to form the electric field (drift) cage. The field cage connections are made using redundant *resistor links*, which are Kapton PCBs with copper traces and resistors imbedded. The cathode is nominally held a voltage of  $-73.38\text{ kV}$  while the anode is grounded. The *wire grid* consists of an octagonal stainless steel frame sitting on top of the TPC barrel (below the anode plate) inset with 150  $\mu\text{m}$  wires spaced 3 mm apart held at a nominal voltage of  $-3.78\text{ kV}$  to create the extraction field. Since the wire grid frame and acrylic components have different thermal contraction coefficients, *concentricity guides* will be machined into every surface where differential thermal contraction occurs, ensuring that the detector as a whole contracts towards the center without obstruction.

The SiPM–based readouts take the form of large octagonal planes positioned above (below) the cathode (anode) plate. The readout is divided into  $20 \times 20\text{ cm}^2$  electromechanical *Photo Detector Units (PDUs)*, each with four readout channels, which are mounted onto stainless steel frames forming the *Optical Planes (OPs)*. Behind the readout layers, held within the frames, 15 cm thick Gd–loaded PMMA pieces form the endcaps of the active neutron veto. Mounted on the opposing side of the frames, as on the exterior of the Gd–loaded barrel wall panels, are the  $20 \times 20\text{ cm}^2$  *Veto Photo Detector Units (VPDUs)* looking towards the reflective inner surface of the stainless steel vessel (covered with poly(ethylene naphthalate) (PEN) and ESR foils).

### 3 The DarkSide–20k Underground Argon (UAr) Cryogenic System

The DS–20k UAr cryogenic system builds on the successful design of the system used for DarkSide–50 [2], which operated for over 8 years. The UAr system is responsible for maintaining the  $\mathcal{O}(100)\text{ t}$  of target material for the direct dark matter search, including continuous purification of the gaseous argon and reliquefaction. Here we focus on a scaled down version (Fig. 2) that was built and tested within the Cryolab at CERN without the nitrogen supply, argon recovery system, purification loop, or radon trap. The complete system Piping and Instrumentation Diagram (P&ID) for DS–20k is included in Appendix A (Fig. 5). The UAr system design is novel and this *testbed* cryogenic system, which contains the core system to be used in DS–20k, was constructed to establish fundamental design function and operational parameters.

### 3.1 Design Overview

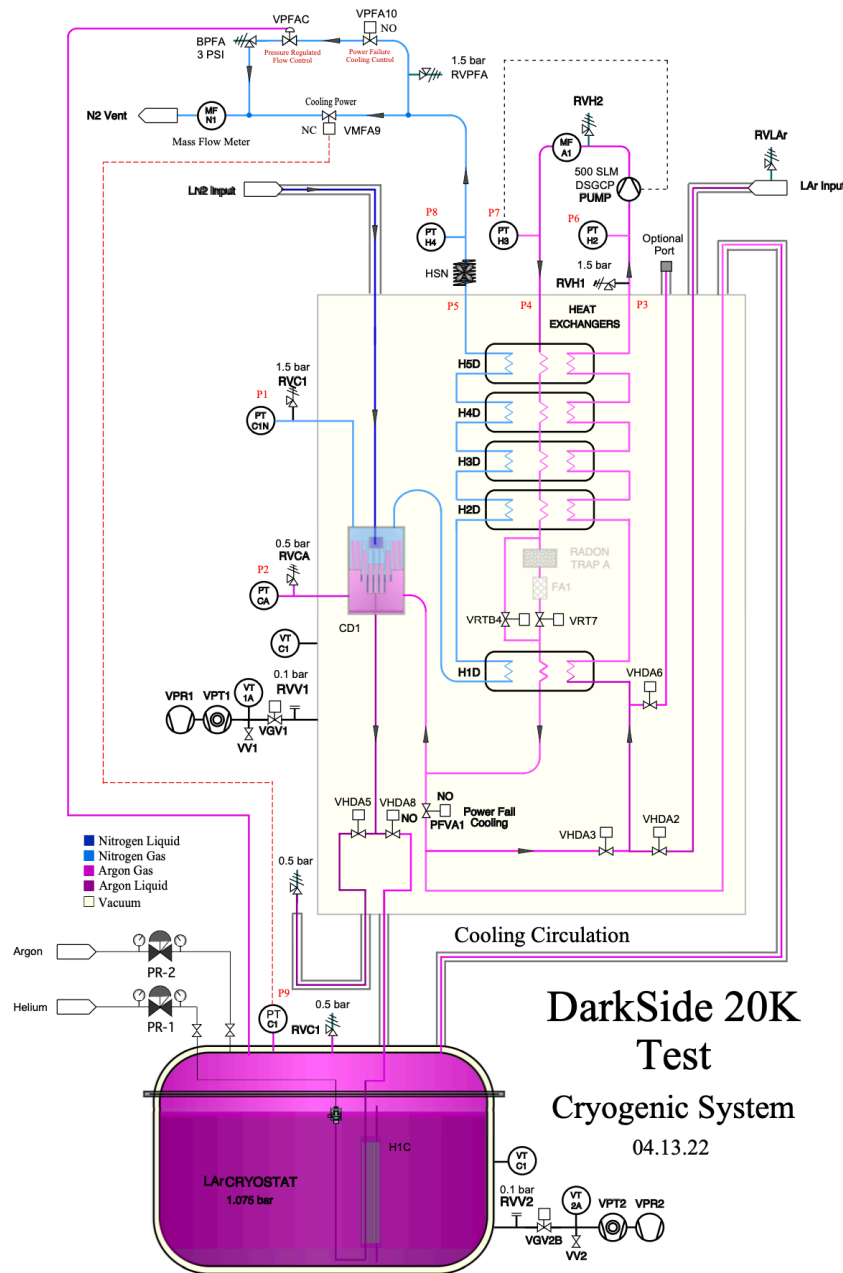

Figure 2: Piping and Instrumentation Diagram (P&ID) of the DS-20k Underground Argon (UAr) cryogenic testbed at CERN. Blue (pink) depicts the nitrogen (argon) pathways.

Figure 2 details the testbed at CERN used for functionality and performance measurements. The *coldbox* is a vacuum insulated vessel depicted by the yellowish inset region, and blue (pink) depicts the nitrogen (argon) pathways. The core of the UAr cryogenic system is the *condenser*, which is the small rectangle labeled as CD1 in Fig. 2. The condenser consists of 1/2-inch stainless steel tubes capped on one end with the other ends welded to a base-plate with 1/2-inch holes. Covers are then welded onto both sides of the base-plate creating a two sided object separated by the tubular geometry for heat exchange.

The condenser principle of operation follows: The tube openings are faced downwards and

gaseous argon (GAr) is flowed to fill the tube volumes. Liquid nitrogen ( $\text{LN}_2$ ) flows steadily onto the top side of the tubes, and latent heat exchange occurs. The condensed argon moves down the inner surfaces of the tubes and is routed into the cryostat, while the gaseous nitrogen is routed out of the top of the condenser. Temperatures and pressures are measured throughout the system, and argon and nitrogen flows are measured at room temperature.

A sophisticated network of parallel plate heat exchangers is employed within the coldbox where gaseous phase heat exchange continues over the entire temperature range from 87 K to room temperature. The exhausted  $\text{N}_2$  gas can be seen routed on the left side of the heat exchangers. The argon pathway is a single closed loop which includes the cryostat and, as argon boils, the cold gas is routed to the bottom–right side of the heat exchangers. A gaseous compressor pump circulates the argon, with the warm gas from the pump being routed down the middle of the heat exchange network, which allows the gaseous argon to be cooled to near liquid temperature before entering the condenser. This design realizes an extremely efficient system with abundant cooling power being recovered from the intrinsic boiling of LAr in the cryostat.

## 3.2 Preliminary Commissioning Results

We present the cooling power recovery efficiency results and describe the detector circulation concept with some first results.

### 3.2.1 Cooling Power Recovery Efficiency

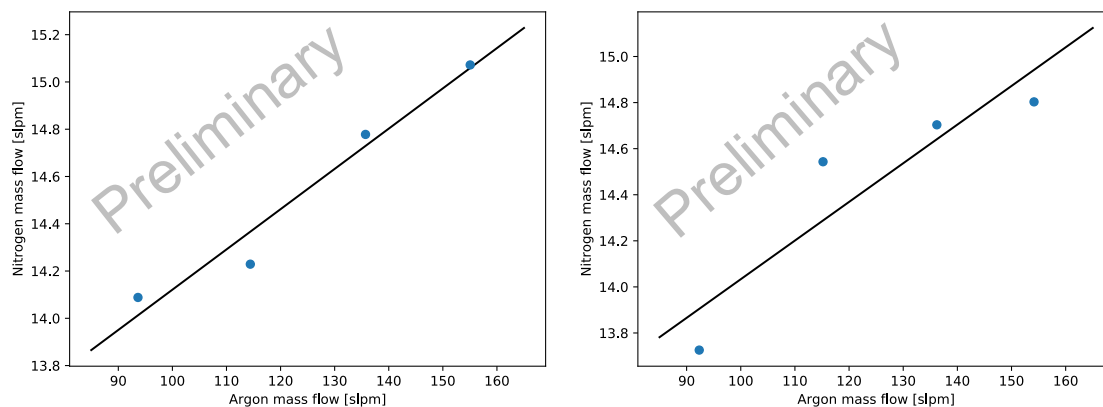

Figure 3: Nitrogen mass flow (consumption) versus argon mass flow. The left (right) panel shows the evaluation of  $\chi^2$  minimization values (blue data points) from the beginning (end) of six-hour runs at four different argon pump speeds. The black solid lines are fits to data points, the slopes of which are averaged to obtain a cooling power recovery efficiency of 99.1%.

Visible inside of the cryostat in Fig. 2 (labeled as H1C) is another parallel plate heat exchange system for detector circulation, which is actually two heat exchangers mounted in parallel. The condenser outlet is routed into one side of heat exchangers, which then passes through a helium–controlled valve into ullage volume of the cryostat. The helium–controlled valve can be used to create a back pressure on the argon outlet, simulating a head pressure which exists in the DS–20k experiment.

For this test the helium valve is not used (no pressure besides that in the ullage is set), and gaseous argon is circulated. The argon compressor is set to various speeds for 12-hour

increments, until the system is well equilibrated. In analysis, 6-hour time periods are chosen where the flows are most stable and  $\chi^2$  minimizations are performed on the flow data. The returned fit parameters are used to evaluate the argon and nitrogen flows at the beginning and end of the 6-hour runs. The results are shown in Fig. 3 as nitrogen flow (consumption) versus argon flow.  $\chi^2$  minimizations are performed on the data in Fig. 3 and the returned slope values are regarded as “consumption rates”, i.e. the amount of nitrogen needed to cool a given amount of argon. The slope values for the beginning and end of the 6-hour runs are averaged to obtain an average consumption rate.

To obtain a value for the cooling power recovery efficiency, we define an efficiency scale in the parameter space of Fig. 3. A zero slope indicates a 100% efficient system. A system with 0% efficiency is defined as the amount of nitrogen needed to cool and condense argon from room temperature. While gas is mainly being circulated here, we assume the argon phase change would be near 100% efficient as it would occur within the heat exchangers in the LAr bulk with the heat from this process generating the detector circulation. We determine our cooling power recovery efficiency to be 99.1%.

### 3.2.2 Detector Circulation

The detector circulation is a crucial parameter for gaseous/liquid detectors because the target volume must be purified at a certain rate in order to perform rare-event physics searches. At a rate of 1000 slpm, the  $\approx 100$  t of UAr in DS-20k can be replaced a couple of times every 40 days. As mentioned in the previous section, a helium-controlled valve is used to simulate the depth that the detector circulation heat exchange system is located within DS-20k. LAr, which has filled the opposing side of the heat exchangers, is boiled to produce the detector circulation for this test.

The helium-controlled valve is pressurized and the compressor speed is increased until the argon pressure within the heat exchanger overcomes the valve pressure. Once argon gas is visibly flowing from the outlet (via a camera mounted inside), liquid is not being condensed and the test is complete. As the compressor speed is incrementally increased, a pressure difference over the heat exchangers is established and the gaseous/liquid argon mixture coming from the condenser is compressed into LAr. As mentioned, the heat from this process boils the LAr on the opposing side of the heat exchangers resulting in a gas supply for the detector circulation. The results are shown in Fig. 4.

## 4 Conclusion

The DS-20k experiment will search for dark matter directly using a dual-phase Time Projection Chamber (TPC), where the target material is argon sourced from underground to exploit the low levels of the radioactive isotope,  $^{39}\text{Ar}$ . The experiment has entered the construction phase at the Gran Sasso Laboratory (LNGS) in central Italy. The novel TPC design uses Gd-loaded PMMA (acrylic) panels for the TPC body, mechanical support for the TPC/veto assembly, and target material for the active neutron veto. The design is in an advanced stage and assembly procedures are being finalized. The core of the Underground Argon (UAr) cryogenic system has been successfully tested at CERN, and the system is now being shipped to LNGS. A cooling power recovery efficiency of 99.1% was measured, and a highly efficient detector circulation method was demonstrated.

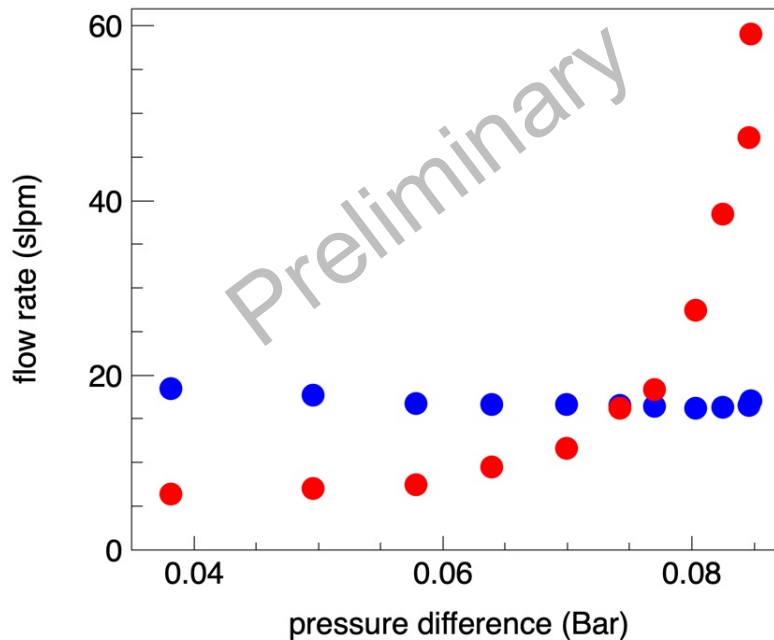

Figure 4: Argon (red circles) and nitrogen (blue circles) flow versus the pressure across the heat exchangers. As the pressure difference increases, the argon flow rises sharply indicating that the gaseous/liquid mixture on one side of the heat exchanger is being condensed. The heat from this process boils LAr on the opposing side of the heat exchangers, producing gas flow for the detector circulation. The nitrogen consumption is essentially flat, indicating this process is highly efficient.

## Acknowledgements

The DarkSide Collaboration would like to thank LNGS, LSC, SNOLAB, Boulby and their staff for invaluable technical and logistical support. We acknowledge the financial support by the Spanish Ministry of Science and Innovation PID2019-109374GB-I00 (MICINN), “Unidad de Excelencia María de Maeztu: CIEMAT - Física de partículas” (Grant MDM2015- 0509), the U. S. National Science Foundation (NSF) (Grants No. PHY- 0919363, No. PHY1004054, No. PHY-1004072, No. PHY-1242585, No. PHY-1314483, No. PHY- 1314507, associated collaborative grants, No. PHY-1211308, No. PHY-1314501, No. PHY-1455351 and No. PHY-1606912, as well as Major Research Instrumentation Grant No. MRI-1429544), the Italian Istituto Nazionale di Fisica Nucleare (Grants from Italian Ministero dell’Istruzione, Università, e Ricerca Progetto Premiale 2013 and Commissione Scientific Nazionale II), the Natural Sciences and Engineering Research Council of Canada, SNOLAB, and the Arthur B. McDonald Canadian Astroparticle Physics Research Institute, LabEx UnivEarthS (ANR-10-LABX-0023 and ANR-18- IDEX-0001), the São Paulo Research Foundation (Grant FAPESP-2017/26238-4), and the Russian Science Foundation Grant No. 16-12-10369, the Polish National Science Centre (Grant No. UMO-2019/33/B/ST2/02884), the Foundation for Polish Science (Grant No. TEAM/2016-2/17), the International Research Agenda Programme AstroCeNT (Grant No. MAB/2018/7) funded by the Foundation for Polish Science from the European Regional Development Fund, the Science and Technology Facilities Council, part of the United Kingdom Research and Innovation, and The Royal Society (United Kingdom). I.F.M.A is supported in part by Conselho Nacional de Desenvolvimento Científico e Tecnológico (CNPq). We also wish

to acknowledge the support from Pacific Northwest National Laboratory, which is operated by Battelle for the U.S. Department of Energy under Contract No. DE-AC05-76RL01830.

## A DS-20k UAr Cryogenic System P&ID

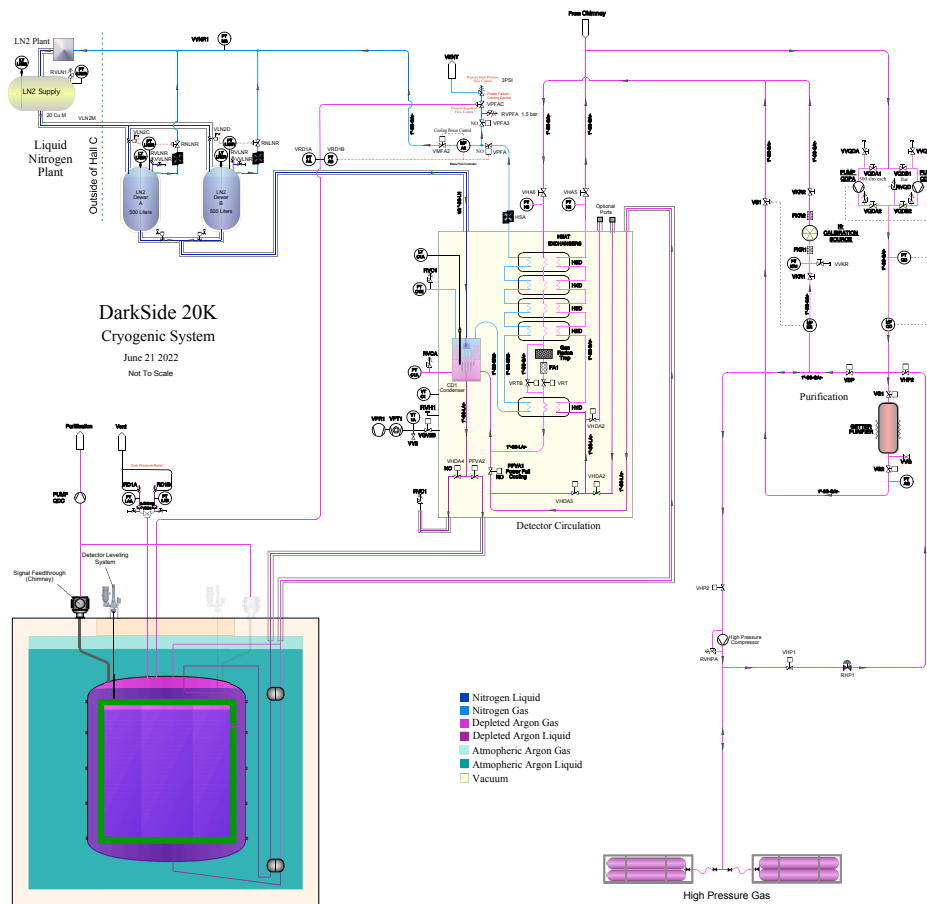

Figure 5: Piping and Instrumentation Diagram (P&ID) of the DS-20k Underground argon (UAr) cryogenic system. The liquid nitrogen and UAr supply systems, along with the purification loop are included.

## References

- [1] P. Agnes, I. F. M. Albuquerque, T. Alexander, A. K. Alton, G. R. Araujo, M. Ave, H. O. Back, B. Baldin, G. Batignani, K. Biery, V. Bocci, G. Bonfini *et al.*, *DarkSide-50 532-day dark matter search with low-radioactivity argon*, *Phys. Rev. D* **98**(10), 102006 (2018), doi:[10.1103/PhysRevD.98.102006](https://doi.org/10.1103/PhysRevD.98.102006).
- [2] P. Agnes, T. Alexander, A. K. Alton, K. Arisaka, H. O. Back, B. Baldin, K. Biery, G. Bonfini, M. Bossa, A. Brigatti, J. P. Brodsky, F. Budano *et al.*, *First results from the DarkSide-50 dark matter experiment at Laboratori Nazionali del Gran Sasso*, *Phys. Lett. B* **743**, 456 (2015), doi:[10.1016/j.physletb.2015.03.012](https://doi.org/10.1016/j.physletb.2015.03.012).